

OPERATOR'S MANUAL

ECHO ENGINE DRILL ED-2000 TYPE 1

WARNING ⚠ DANGER

READ INSTRUCTIONS CAREFULLY AND
FOLLOW RULES FOR SAFE OPERATION.
FAILURE TO DO SO COULD RESULT IN
SERIOUS INJURY.

ECHO, INCORPORATED

400 Oakwood Road, Lake Zurich, Illinois 60047
Phone : 708-540-8400



898611-09060
X750409-2401

 **WARNING** 

The engine exhaust from this product contains chemicals known to the State of California to cause cancer, birth defects or other reproductive harm.

INTRODUCTION

ECHO Engine Drill ED-2000 is a lightweight, high performance, two-stroke engined unit designed for drilling.

This Manual provides the information necessary for operation and maintenance.

WARNING **DANGER**

IMPROPER USE OR CARE OF THIS UNIT, OR FAILURE TO WEAR PROPER PROTECTION CAN RESULT IN SERIOUS INJURY. READ AND UNDERSTAND THE RULES FOR SAFE OPERATION AND ALL INSTRUCTIONS IN THIS MANUAL.

SAFETY AND SPECIAL INFORMATION



THIS SYMBOL ACCOMPANIED BY THE WORDS WARNING AND DANGER CALLES ATTENTION TO AN ACT OR CONDITION THAT CAN LEAD TO SERIOUS PERSONAL INJURY TO OPERATOR AND BYSTANDERS.

IMPORTANT

The enclosed message provides information necessary for the protection of the unit.

NOTE

This enclosed message provides tips for use, care and maintenance of the unit.



The circle with the slash symbol means whatever is shown within the circle is prohibited.

Throughout this manual and on the product itself, you will find safety alters and helpful, information messages preceded by symbols or key words. The following is an explanation of those symbols and key words and what they mean to you.

CONTENTS

Introduction	1
Safety and Special Information	1
Safety	2
Operating Techniques	5
Description	6
Assembling	7
Operation	7
Maintenance and Care	9
Trouble shooting	10
Maintenance	11
Storage	13
Specifications	14

Specifications, descriptions and illustrative material in this literature are as accurate as known at the time of publication. Illustrations may include optional equipment and accessories, and may not include all standard equipment.

SAFETY

WARNING **DANGER**

ENGINE DRILL USERS RISK INJURY TO THEMSELVES AND OTHERS IF THE ENGINE DRILL IS USED IMPROPERLY, AND/OR SAFETY PRECAUTIONS ARE NOT FOLLOWED. PROPER CLOTHING AND SAFETY GEAR MUST BE WORN WHEN OPERATING ENGINE DRILL.

WARNING **DANGER**

ALWAYS STOP THE ENGINE WHEN A DRILL JAM OCCURS. DO NOT ATTEMPT TO REMOVE AN OBJECT CAUSING A DRILL JAM IF THE ENGINE IS RUNNING. PHYSICAL INJURY CAN OCCUR IF A DRILL JAM IS REMOVED AND THE DRILLS START MOVING.

OPERATOR SAFETY

- Read this Engine drill Operator's Manual carefully. Be sure you understand how to operate this unit properly before you use it.
- Be familiar with all the controls and the proper use of the machine.
- Wear proper clothing to protect legs and other exposed parts of your body.
- Wear non-skid sole shoes. Do not wear open-toed shoes or operate unit while bare footed.
- Wear eye and hearing protection devices.
- Use caution when handling fuel. Put the caps back tightly on both the fuel can and the engine drill fuel tank. Move at least 3 meters (10 feet) from the re-fuelling point and be sure there is no leakage of fuel from the fuel tank cap or the fuel system before starting the engine.
- Operate this gasoline powered engine equipment in a well-ventilated area only.
- Start the unit on the ground with the throttle set at idle. Do not start if the drills are obstructed by the ground or any other object.
- Never allow children to use the machine.
- Do not allow anyone to hold the material you are drilling.
- Keep a firm grip on the engine drill with both hands, the right hand on the front handle, the left hand on the rear handle.

- Do all drilling at full throttle speed. Drilling at less than full speed can damage the clutch by allowing it to slip.

WARNING **DANGER**

USE A FIRM GRIP WITH THUMBS AND FINGERS ENCIRCLING THE HANDLES. A FIRM GRIP WILL HELP YOU KEEP CONTROL OF THE ENGINE DRILL. NEVER OPERATE THE ENGINE DRILL ONLY ONE HAND OR BODILY INJURY CAN OCCUR.

- Always carry the engine drill with the engine stopped and the HOT muffler away from your body.

PROTECTIVE EQUIPMENT

- Always wear eye protection goggles that meet ANSI Z87.1 standards.
- Wear hearing protection. ECHO recommends that hearing protection be worn at all times.
- Dress properly! Do not wear loose clothing or jewellery, they can be caught in moving parts. Use of sturdy gloves, non-skid footwear, and safety glasses is recommended.
- While operating the machine always be sure of a secure position.

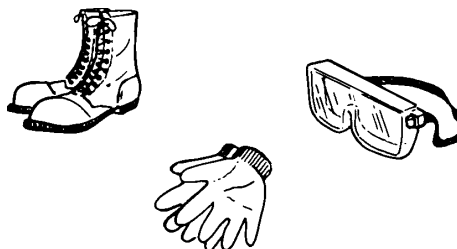

- Wear non-slip, heavy-duty work gloves to improve your grip on the engine drill handles. The gloves also help reduce the transmission of machine vibrations to your hands.

PROTECTING OTHERS

Spectators, children, fellow workers and animals must be warned to come no nearer than 4.6 meters (15 feet) while the engine drill is in use.

People working in the area near you should wear the same protective equipment as the operator.



PHYSICAL CONDITION

Your judgement and dexterity may be impaired if you are ill or have taken alcohol or other substances known to affect the way you would normally function.

EXTENDED OPERATION/ EXTREME CONDITIONS

Vibration and Cold

It is believed that a condition called Raynaud's Phenomenon, which affects the fingers of certain individuals may be brought about by exposure to vibration and cold. Exposure to vibration and cold may cause tingling and burning sensations followed by loss of color and numbness in the fingers. The following precautions are strongly recommended because the minimum exposure which might trigger the ailment is unknown.

- Keep your body warm, especially the head, neck, feet, ankles, hands and wrists.
- Maintain good blood circulation by performing vigorous arm exercises during frequent work breaks and also by not smoking.
- Limit the hours of operation. Try to fill each day with jobs where operating the engine drill or other hand-held power equipment is not required.
- If you experience discomfort, redness and swelling of the fingers followed by whitening and loss of feeling, consult your physician before further exposing yourself to cold and vibration.

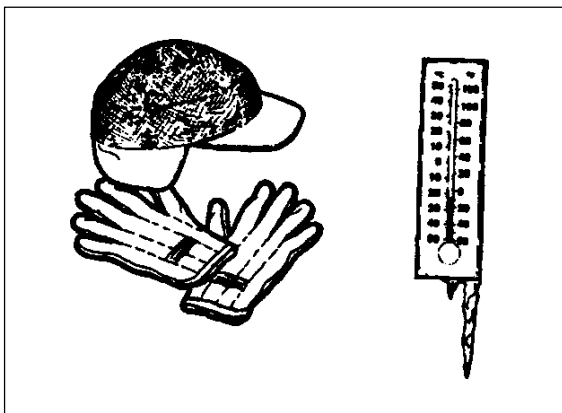

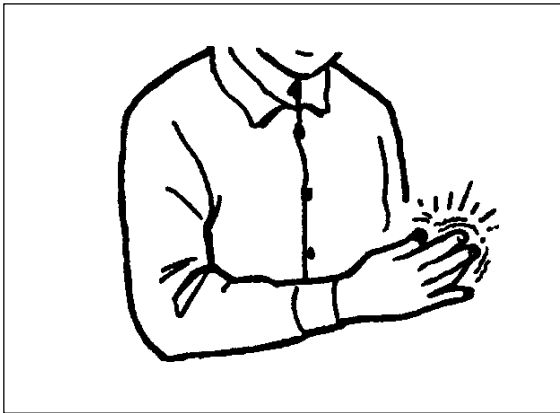
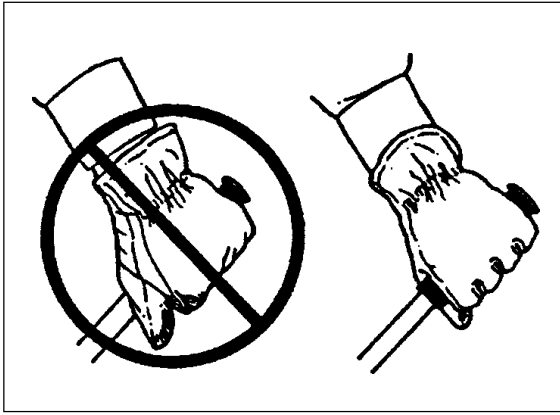

Repetitive Stress Injuries

It is believed that overusing the muscles and tendons of the fingers, hands, arms and shoulders may cause soreness, swelling, numbness, weakness and extreme pain in those areas. Certain repetitive hand activities may put you at a high risk for developing a Repetitive Stress Injury (RSI). An extreme RSI condition is Carpal Tunnel Syndrome (CTS), which could occur when your wrist swells and squeezes a vital nerve that runs through the area. Some believe that prolonged exposure to vibration may contribute to CTS. CTS can cause severe pain for months or even years. To reduce the risk of RSI/CTS, do the following:

- Avoid using your wrist in a bent, extended or twisted position. Instead try to maintain a straight wrist position. Also, when grasping, use your whole hand, not just the thumb and index finger.
- Take periodic breaks to minimize repetition and rest your hands.
- Reduce the speed and force with which you do the repetitive movement.
- Do exercise to strengthen the hand and arm muscles.
- See a doctor if you feel tingling, numbness or pain in the fingers, hands, wrists or arms. The sooner RSI/CTS is diagnosed, the more likely permanent nerve and muscle damage can be prevented.

OPERATING TECHNIQUES

- When starting to drill, run the engine at full throttle.

WARNING  DANGER
BEFORE DRILLING, BE SURE TO READ AND UNDERSTAND THE ENTIRE OPERATOR'S MANUAL TO AVOID THE CHANCE OF SERIOUS INJURY.

- Do not force the drills and only move as quickly as the drills will allow.
 - Stop the engine and disconnect from ignition cable before: - cleaning or when clearing a blockage; checking, maintenance or working on the machine.
 - Handle fuel with care; it is highly flammable. Never add fuel to a machine with a running or hot engine.
 - Do not attempt to repair the machine unless you are qualified to do so.
 - Do not operate the machine with a damaged or excessively worn cutting device.
 - Always ensure all handles and guards are fitted when using the machine. Never attempt to use an incomplete machine or one fitted with an unauthorised modification.
- When transporting or storing the machine always remove the drill.
 - To reduce fire hazard keep engine and silencer free of debris, leaves or excessive grease.
 - Handle drill with care, contacting with drills may cause injury.

DESCRIPTION

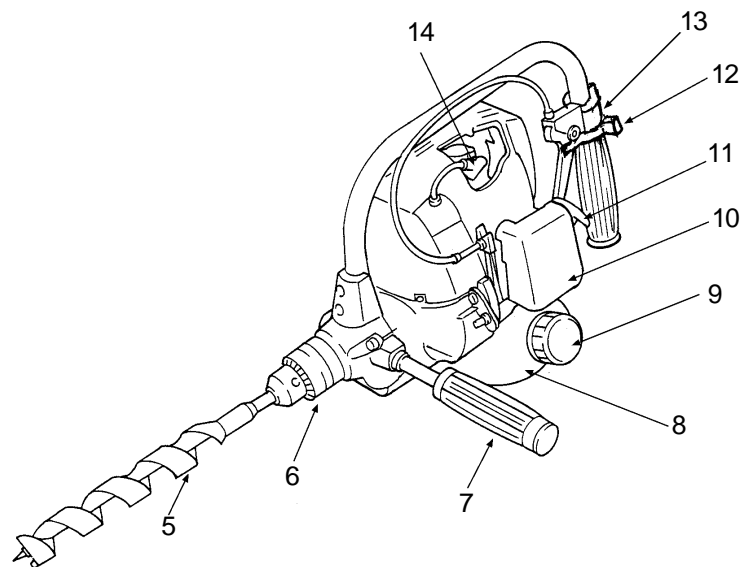
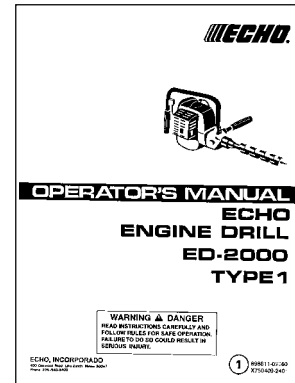
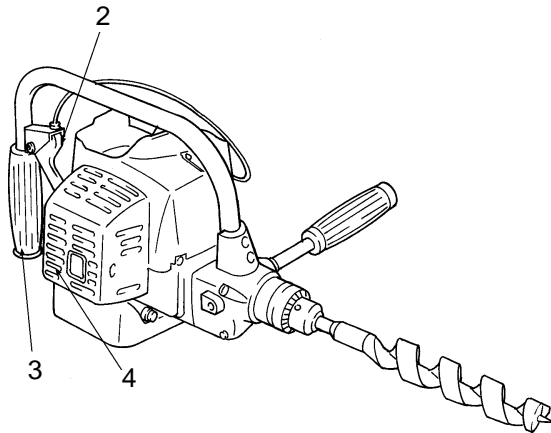

1. **Operator's manual** - Included with unit. Read before operation and keep for future reference to learn proper, safe operating techniques.
2. **Throttle trigger** - Device activated by the operator's finger, for controlling the engine speed.
3. **Rear handle** - Handle located furthest from the cutting device.
4. **Silencer cover**
5. **Drill** - Not included with unit.
6. **Chuck** -
7. **Front handle** - Handle located on the front gear case.
8. **Fuel tank** - Contains fuel and fuel filter.
9. **Fuel tank cap** - Covers and seals fuel tank
10. **Air cleaner cover** - Covers and seals air filter.
11. **Starter handle** - Pull handle to start the engine.
12. **Throttle trigger lock out** - Device that prevents the accidental operation of the throttle trigger until manually released.
13. **Ignition switch** - Device for allowing the engine to be started and stopped.
14. **Spark plug**

ASSEMBLING

FRONT HANDLE

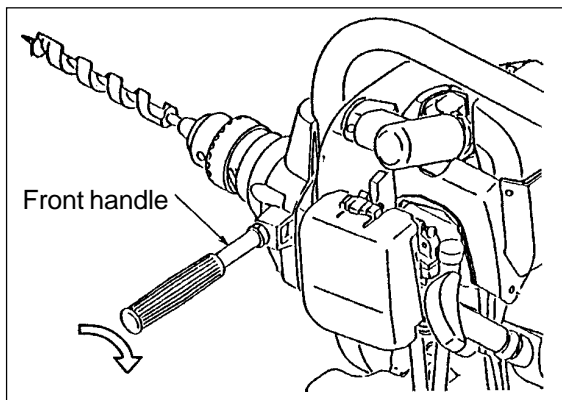

- Insert the front handle to the machine, and turn clockwise.
(TIGHTEN THE SCREW FIRMLY)

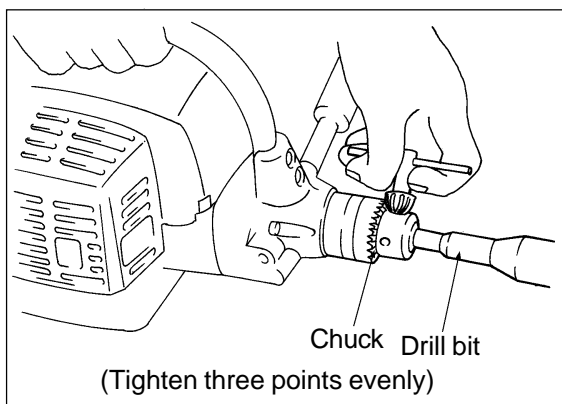

DRILL BIT

- Insert the drill bit (not provided with unit) until it reaches the bottom of the chuck, then back it out slightly; tighten the chuck laws evenly and completely.

IMPORTANT

Use drill bits suited for the material being drilled and for the depth of hole required.

OPERATION

CHECK UP OF NUTS AND OTHER HARDWARES

- Check up loose nuts, bolts and screws before using the unit every day.

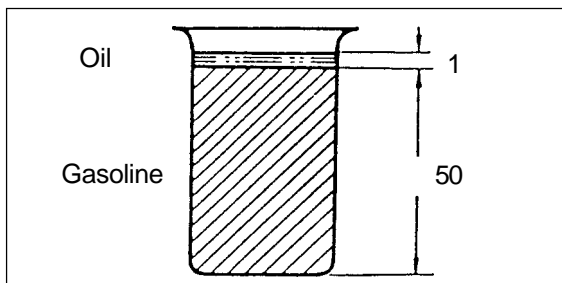

FUEL STATEMENT

GASOLINE - Use 89 Octane [(R+M)/2] gasoline or gasohol known to be good quality- Gasohol may contain maximum 10% ethyl (grain) alcohol or 15% MTBE (methy tertiary- butyl ether). Gasohol containing methyl (wood) alcohol is not approved.

OIL - ECHO brand premium two-strokes 50:1 oil is preferred. Mix oil and gasoline/gasohol according to Instructions on the oil container label.

MIXING - Follow directions on the container.

Fuel mix chart (50 : 1)

US		METRIC	
GAS	OIL	GAS	OIL
GAL.	FL.OZ.	LITERS	CC
1	2.6	4	80
2	5.1	8	160
5	12.8	20	400

IMPORTANT

Stored fuel ages. Do not mix more fuel than you expect to use in thirty (30) days, ninety (90) days when a fuel stabilizer is added.

Stored two-stroke fuel may separate. ALWAYS shake fuel container thoroughly before each use.

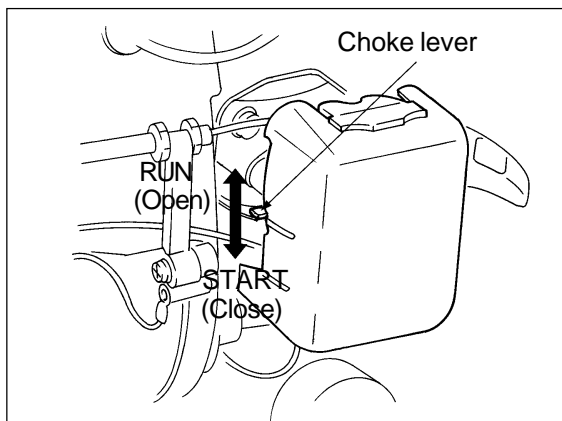
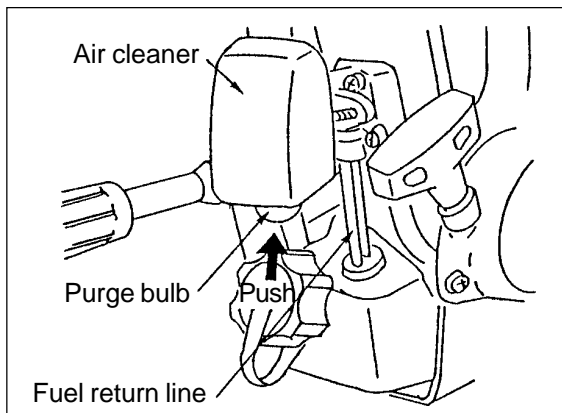
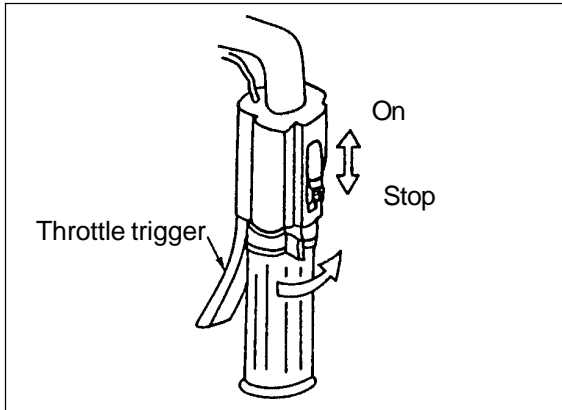

STARTING COLD ENGINE

- Stand the engine upright on a level surface.
- Slide ignition switch to "ON" position. (START/RUN)
- Push purge bulb 3 to 4 times (or until fuel is visible in fuel return line).
- Shift choke shutter to close position. (START)
- Open throttle trigger to a fast idle.
- Pull recoil starter until the engine fires.
- Shift choke shutter to full open position, and if necessary, start the engine again and allow to warm up before using.
 - The clutch engages at approximately 3500 rpm. therefore the cutter may rotate at fast idle engine speed.

STARTING WARM ENGINE

- Ignition switch to "ON" position.
- Pull starter handle until the engine fires.
 - Do not use the choke.

STOPPING ENGINE

- Set throttle trigger in idle position.
- Slide ignition switch to "STOP" position.

NOTE

When engine does not stop, shift choke shutter to close position. Check and repair stop switch before starting the engine again.

MAINTENANCE AND CARE

AREA	MAINTENANCE	PAGE	BEFORE USE	MONTHLY	YEARLY	DATE MAINTENANCE PERFORMED
Air Filter	Clean/Replace	11	•			
Fuel Filter	Inspect/Replace	11		•		
Spark Plug	Inspect/Clean/ Adjust/Replace	11		•		
Carburettor	Adjust	12			•	
Cooling System	Inspect/Clean	12	•			
Silencer	Inspect/Clean	12		•		
Starter Rope	Inspect/Replace	-		•		
Drills	Inspect/Clean/ Lubricate	-			•	
Fuel Leaks	Inspect/Repair	-	•			
Screw, Bolts & Nuts	Inspect, Tighten/Replace	-	•			
Fuel Line	Inspect	-		•		

IMPORTANT

Time intervals are maximum. Actual use and your experience will determine the frequency of required maintenance. Record dates of monthly and yearly inspections.

TROUBLESHOOTING

Trouble		Cause	Remedy
Engine - starts hard - does not start			
Engine Cranks ↓	Fuel at carburettor → No fuel at carburettor	<ul style="list-style-type: none"> • Fuel strainer clogged • Fuel line clogged • Carburettor 	<ul style="list-style-type: none"> • Clean. • Clean. • See your Echo dealer
	Fuel at cylinder → No fuel at cylinder	<ul style="list-style-type: none"> • Carburettor 	<ul style="list-style-type: none"> • See your Echo dealer
	Silencer wet with fuel	<ul style="list-style-type: none"> • Fuel mixture is too rich 	<ul style="list-style-type: none"> • Open choke • Clean/replace air filter • Adjust carburettor • See your Echo dealer
	Spark at end of plug wire → No spark at end of plug wire	<ul style="list-style-type: none"> • Ignition switch off • Electrical problem 	<ul style="list-style-type: none"> • Turn switch on • See your Echo dealer
	Spark at plug → No spark at plug	<ul style="list-style-type: none"> • Spark gap incorrect • Covered with carbon • Fouled with fuel • Spark plug defective 	<ul style="list-style-type: none"> • Adjust 0.6-0.7 mm (0.024-0.028in.) • Clean or replace • Clean or replace • Replace plug
Engine does not crank		<ul style="list-style-type: none"> • Internal engine problem 	<ul style="list-style-type: none"> • See your Echo dealer
Engine runs ↓	Dies or accelerates poorly ↓	<ul style="list-style-type: none"> • Air filter dirty • Fuel filter dirty • Fuel vent blocked • Spark plug • Carburettor • Cylinder fins blocked • Exhaust port/spark arrester screen blocked 	<ul style="list-style-type: none"> • Clean or replace • Replace • Clean • Clean and adjust/replace • Adjust • Clean • Clean

WARNING DANGER

ALL ENGINE DRILL SERVICING, OTHER THAN THE ITEMS LISTED IN THE OPERATOR'S MANUAL SHOULD BE PERFORMED BY AN AUTHORIZED ECHO DEALER.

MAINTENANCE

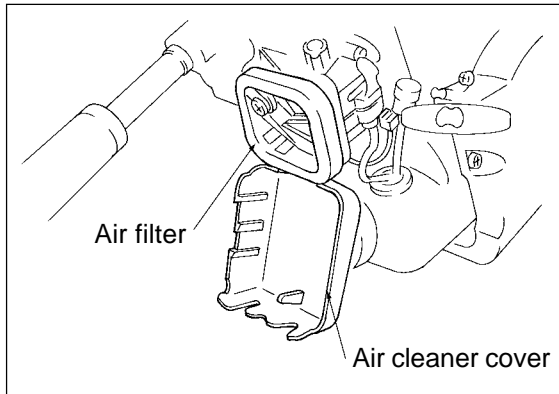

AIR FILTER

- Clean before Use.
 - Remove air cleaner cover and pull out air filter.
 - Lightly brush off dust or wash it in water and detergent.
 - Dry completely before putting it back in place.

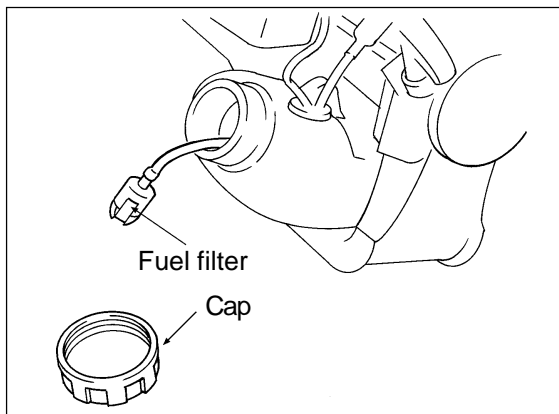

FUEL FILTER

- Check periodically.
 - Do not allow dust to enter into fuel tank.
 - Clogged filter will cause difficulty in starting engine or poor engine performances.
 - Pick up fuel strainer through fuel inlet port with a piece of steel wire or the like.
 - When filter is dirty, replace it.

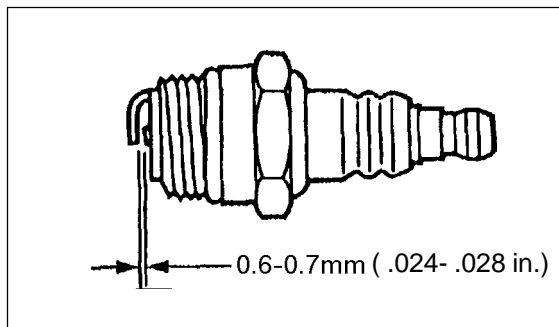

SPARK PLUG

- Check periodically.
 - The standard spark gap is 0.6 - 0.7 mm (0.023 - 0.028 in.).
 - Correct spark gap if it is wider or narrower than the standard gap.
 - If the electrodes are coated with carbon deposits replace with a new spark plug. Do not sandblast to clean. Remainng sand will damage engine.
- Fastening torque = 145 - 155kg-cm (125 - 135 in-lb)

IMPORTANT

Do not over tighten plug.

ADJUSTING CARBURETTOR (As Required)

GENERAL INFORMATION

The idle speed adjuster screw controls the throttle opening at the idle position.

IDLE ADJUSTMENT

1. Start engine and allow it to run at high idle until warm.
2. Turn the idle speed screw clockwise until drill begins to move.
3. Turn idle screw counter-clockwise 1-1/2~2 turn or until the drill stops (2,700 ~ 3,300 rev/min).

CLEANING CYLINDER FINS (Check Periodically)

NOTE

Clogged fins will cause poor engine cooling.

1. Carefully remove housing and clean dirt and dust from fins.
2. Reinstall housing.

CLEANING SILENCER AND EXHAUST PORT (Check Periodically)

1. Carefully remove housing halves.
2. Remove and disassemble silencer.

NOTE

Be careful not to scratch the cylinder or piston when cleaning the cylinder exhaust port.

3. Clean deposits from cylinder exhaust port and silencer.

STORAGE

LONG TERM STORAGE (Over 30 Days)

Do not store your unit for a prolonged period of time (30 days or longer) without performing protective storage maintenance which includes the following:

1. Store unit in a dry, dust free place, out of the reach of children.
2. Place the ignition switch in the STOP position.
3. Remove accumulation of grease, oil, dirt and debris from exterior of unit.
4. Perform all periodic lubrication and services that are required.
5. Tighten all the screws and nuts.

WARNING  **DANGER**
DO NOT STORE IN ENCLOSURE WHERE FUEL FUMES MAY ACCUMULATE OR REACH AN OPEN FLAME OR SPARK.

6. Drain the fuel tank completely and pull the starter handle several times to remove fuel from the carburettor.
7. Remove the spark plug and pour 1/2 tablespoon (1/4 oz) of fresh, clean, 2-stroke engine oil into the cylinder through the spark plug hole.
 - A. Place a clean cloth over the spark plug hole.
 - B. Pull the starter handle 2-3 times to distribute the oil inside the engine.
 - C. Observe the piston location through the spark plug hole. Pull the starter slowly until the piston reaches the top of its travel and leave it there.
8. Install the spark plug (do not connect ignition cable.)
9. Lubricate the blades with a heavy coat of oil to prevent rust.

NOTE

For future reference, you should keep this operator's manual.

SPECIFICATIONS

		ED-2000 TYPE1
Masses	kg	4.0 (8.8)
Volume fuel tank	ℓ	0.5 (16.9 FL,OZ,US)
Drill size (Max) chuck capacity speed	mm mm r.p.m	30 13 (0.5 inch) 430
Mission reduction ratio lubrication		20 :1 grease
External Dimensions length x width x height	mm	380 x 328 x 255 (14.9 x 12.8 x 10.0 inch)
Engine type engine displacement carburettor ignition spark plug starter clutch	cm ³	Air cooled Two stroke single cylinder 21.2 (1.29 cu.inch) diaphragm type flywheel magneto - CDI system NGK BPM7Y recoil starter automatic Centrifugal
Fuel mixing ratio fuel consumption at engine maximum power	 ℓ /h	 Mixture of gasoline (unleaded, 89 octane minimum) and specially blended 50:1 ECHO two cycle engine oil. 0.5 (16.9 FL,OZ,US)