

ECHO[®]

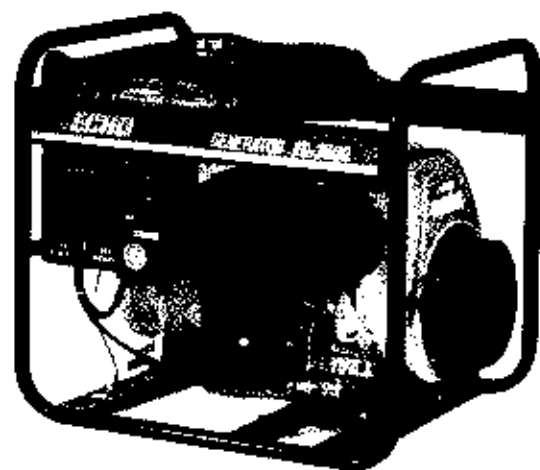

OPERATOR'S MANUAL

ECHO GENERATORS

EG-1500

EG-2300

EG-3500

EG-4300

CAUTION

Read Rules for safe Operation
and Instructions Carefully.



898 560-8036 0

Thank you for purchasing an ECHO Generator. This manual covers operation and maintenance of models EG-1500, EG-2300, EG-3500 and EG-4300.

All information in this publication is based on the latest product information available at the time of approval for printing. ECHO, INCORPORATED reserved the right to make changes at anytime without notice and without incurring any obligations.

This manual should be considered a permanent part of the generator and should remain with a unit when it is sold. Please pay special attention to statements preceded with warning or cautions, they indicate a possibility of personal injury or equipment damage if instructions are not followed.

CAUTION:

Before starting engine for the first time, add oil as unit is shipped dry.

FILL OUT AND KEEP FOR YOUR OWN RECORD		
Model No. _____	Serial No. _____	Purchase Date _____
Bill Of Sale No. _____	Payment record (Check No., etc.) _____	
Dealer _____		
Street or RFD _____		
City _____	State _____	Zip _____
Any part claimed to be defective must be returned by delivering it to an authorized ECHO dealer or distributor.		

CONTENTS

1.	SPECIFICATIONS	1
2.	GENERAL IDENTIFICATIONS	2
	Models EG-1500/EG-2300	2
	Model EG-3500	3
	Model EG-4300	4
3.	SAFETY INSTRUCTIONS	5
	Learn Generator Safety / Protect People and Pets / Handle Fuel Safety / Operate Engine/Generator Safely / Respect Electricity / Service and Store Generator Safely / Have an Extinguisher Nearby / Personal Precautions When Charging Batteries / Risk of Explosive Gases / Charging Batteries	
4.	FUELS AND LUBRICANTS	11
	Engine Oil	11
	Fuel	11
	Servicing Set Up of New Unit or Changing Engine Oil	12
5.	WATTAGE CALCULATING INSTRUCTIONS	13
	Maximum Output Operation	14
	Extension Cord – Usage	14
	Miscellaneous Wattage Requirements	15
6.	PRESTARTING INFORMATION	17
	Grounding Generator / Power Indicator Pilot Light / AC Receptacles – Circuit Breakers – Fuses / Connecting 120 V Receptacles / Connecting 240 V Receptacle / Connecting 12 VDC Receptacles / Maximum Output Operation / AC Receptacles and Fuses - EG-1500 / AC Receptacles – Circuit Breaker – Fuses - EG-2300 / –EG-3500 / –EG-4300 / Operating Generator/AC Output / DC Receptacles and Fuses / Using Generator as Booster / Operating Generator/DC Output	
7.	CHARGING BATTERIES	23
	Prevent Battery Explosions / Avoid Acid Burns / Prepare the Battery / Check Battery Specific Gravity / Connecting Generator to Battery or Equipment / Stopping and Disconnect Generator from Battery or Equipment / Charging Time	
8.	PRESTART CHECKS AND OPERATING THE ENGINE	26
	Starting the Engine / Breaking in a New Engine / Engine Break in Requirements / Cold Start / Starting the Engine / Low Oil Level Shutdown System / Stopping the Engine	
9.	GENERAL MAINTENANCE	29
	Service/Before Each Use / Checking Engine Oil Level / Cleaning Air Filter Element / Air Filter Service / Spark Plug Maintenance / Fuel Tank Strainer / Fuel Valve/Fuel Bowl / Spark Arrester Screen- Exhaust Outlet	
10.	STORAGE	34
	Storing for Short Time between Jobs (90 days or less) Storing for Long Time between Jobs (longer than 90 days) Removing Generator from Storage	
11.	PREVENTIVE MAINTENANCE CHECK CHART	35
12.	TROUBLESHOOTING	36
	LIMITED WARRANTY	

Specifications

SPECIFICATIONS

DESCRIPTION		EG1500	EG2300	EG3500	EG4300
Engine Type		4-cycle, air-cooled			
Engine Model		GE36DGY	GE50DGY	GE75DGY	GE90DGY
Displacement	cc/cu in	144/8.7	192/11.6	277/16.7	365/22.0
Frequency	Hz	60	60	60	60
Rated Output Watts AC Continuous Duty		1300	2000	3050	3800
Output Max. Watts AC		1450	2200	3300	4300
Engine Speed	RPM	3600	3600	3600	3600
Voltage	V	120	120	120/240	120/240
Output DC		12 Volts 100 Watts	12 Volts 100 Watts	—	—
Starting System		Recoil	Recoil	Recoil	Recoil
Fuel Tank Capacity:	Liters US Gal.	5.6 1.5	11.0 3.0	11.0 3.0	11.0 3.0
Continuous Operation Hours Per Tank		4.3	7.3	4.5	3.5
Ignition		Transistorized			
DC Battery Charging Cable		Yes	Yes	—	—
Automatic Voltage Regulator		Yes	Yes	Yes	Yes
AC Circuit Breaker		— (Fuse)	Yes	Yes	Yes
DC Fuse		Yes	Yes	—	—
Carburetor		Float	Float	Float	Float
AC Receptacles	Unit/Volt (Amp)	2/120V (10.8A)	2/120V (16.6A)	2/120V - 2/240V (25A) (25A)	3/120V - 2/240V (31.7A) (15.8A)
DC Receptacle		1	1	—	—
Spark Plug		BPM4A L-90 Champion or equivalent		BPM4A L-90 Champion or equivalent	
Oil Crankcase Capacity	Liters Ounces	0.5 17.0	0.55 18.7	0.95 32.4	1.25 42.6
Oil Alert		Yes	Yes	Yes	Yes
Spark Plug wrench with Driver		1	1	1	1
Dimension (LxWxH)	mm (inches)	455 x 355 x 455 (17.9x14.0x17.9)	490 x 355 x 475 (19.3x14.0x18.7)	572 x 450 x 510 (22.5x17.7x20.0)	600 x 450 x 535 (23.6x17.7x21.1)
Weight	kg (lbs)	30 66.2	39 86.0	54 119.0	65.5 144.4

General Identifications

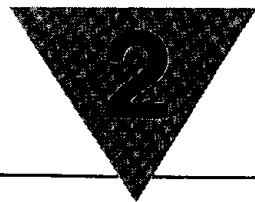

GENERAL IDENTIFICATION OF PARTS AND CONTROLS 120V-AC and 12V-DC MODELS EG-1500, EG-2300 ONLY

1. Fuel Cap
2. Fuel Tank
3. Throttle/Choke Lever
4. Air Filter
5. Tube/Handle Frame
6. Shock Mounting System
7. Muffler
8. Spark Arrester Screen
9. Receptacle Panel
10. AC 120-Volt Receptacles
11. Circuit Breaker (EG-2300 only)
12. Fuse (AC)
13. Generator Housing
14. DC 12-Volt Receptacle
15. Ignition ON/OFF Switch
16. Oil Filler Cap/Distick
17. Spark Plug
18. Fuel Shut Off Valve
19. Fuel Filter/Bowl
20. Starter Housing
21. Starter/Rope Handle
22. Grounding Lug
23. Oil Drain Plug
24. Fuse (DC)
25. Oil Alert Lamp
26. Oil Alert Sensor Unit
27. Power Indicator Lamp

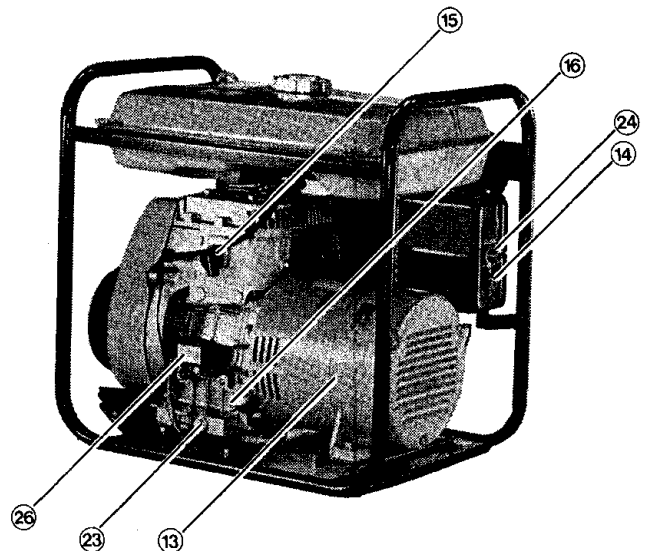
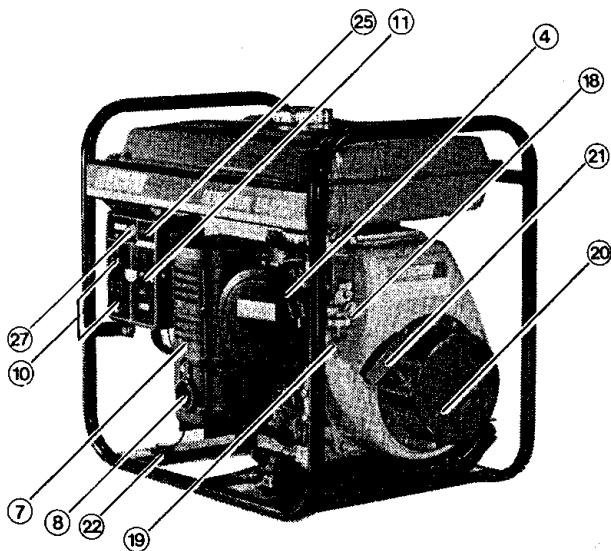
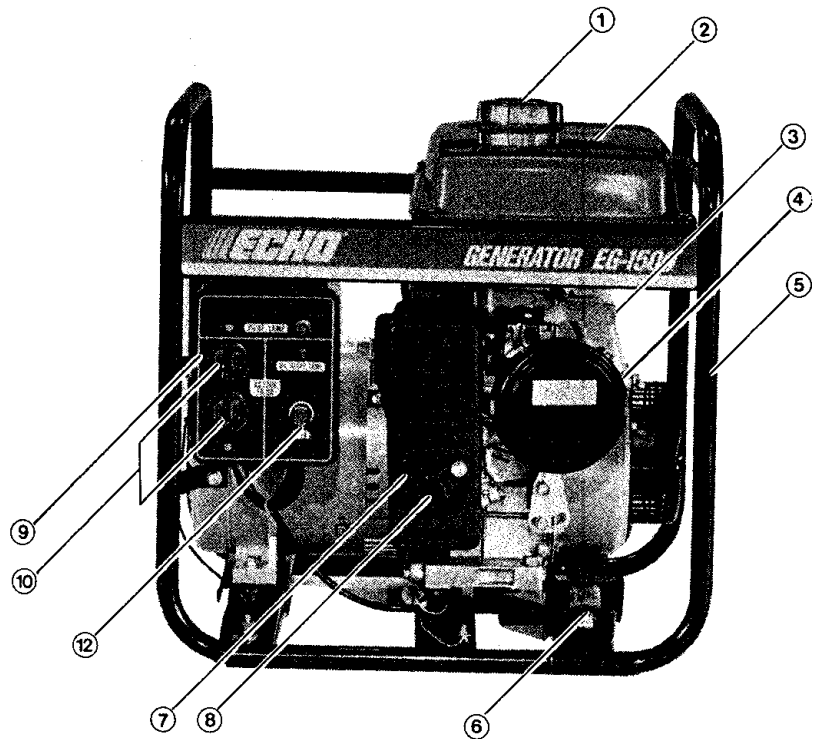

General Identifications

GENERAL IDENTIFICATION OF PARTS AND CONTROLS 120V-AC and 240V-AC MODEL EG-3500 ONLY

1. Fuel Tank Cap
2. Fuel Tank
3. Handle/Tube Frame
4. Air Filter
5. Throttle/Choke Lever
6. Muffler Assembly
7. Exhaust Port/Spark Arrester Screen
8. Receptacle Panel
9. Oil Alert Lamp
10. Circuit Breaker
11. AC 120/240-Volt Receptacles
12. Generator Housing
13. Cradle/Mounting System
14. Fuel Line
15. Generator Vents
16. Oiler Filler Cap/Dipstick
17. Fuel Bowl/Filter
18. Fuel Shut Off Valve
19. Starter Housing
20. Starter Handle
21. Ignition ON/OFF Switch
22. Grounding Lug
23. Oil Drain Plug
24. Oil Alert Sensor Unit
25. Change Over Switch
26. Power Indicator Pilot Lamp
27. 15 Amp Fuse

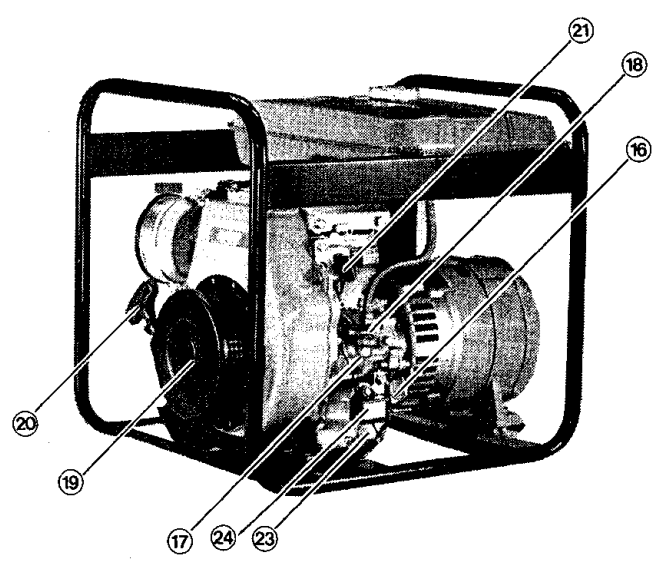
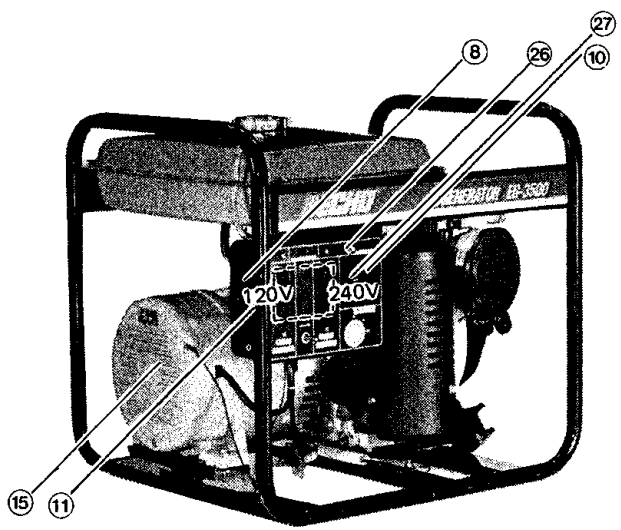
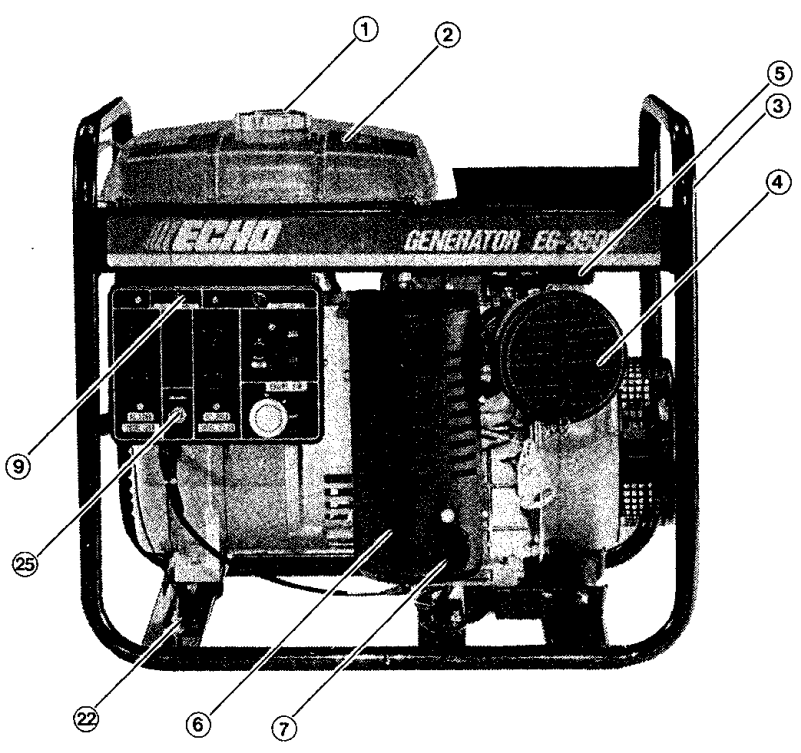

General Identifications

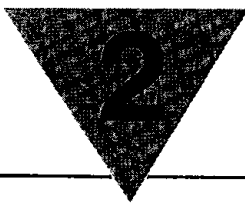

GENERAL IDENTIFICATION OF PARTS AND CONTROLS 120V-AC and 240V-AC MODEL EG-4300 ONLY

1. Fuel Tank Cap
2. Fuel Tank
3. Handle/Tube Frame
4. Air Filter
5. Throttle Lever/Choke Lever
6. Muffler Assembly
7. Exhaust Port/Spark Arrester Screen
8. Receptacle Panel
9. Oil Alert Lamp
10. Circuit Breaker
11. AC 120/240-Volt Receptacles
12. Generator Housing
13. Cradle/Mounting System
14. Fuel Line
15. Generator Vents
16. Oiler Filler Cap/Dipstick
17. Fuel Bowl/Filter
18. Fuel Shut Off Valve
19. Starter Housing
20. Starter Handle
21. Ignition ON/OFF Switch
22. Grounding Lug
23. Oil Drain Plug
24. Oil Alert Sensor Unit
25. Change Over Switch
26. Power Indicator Pilot Lamp
27. 20 Amp Fuse

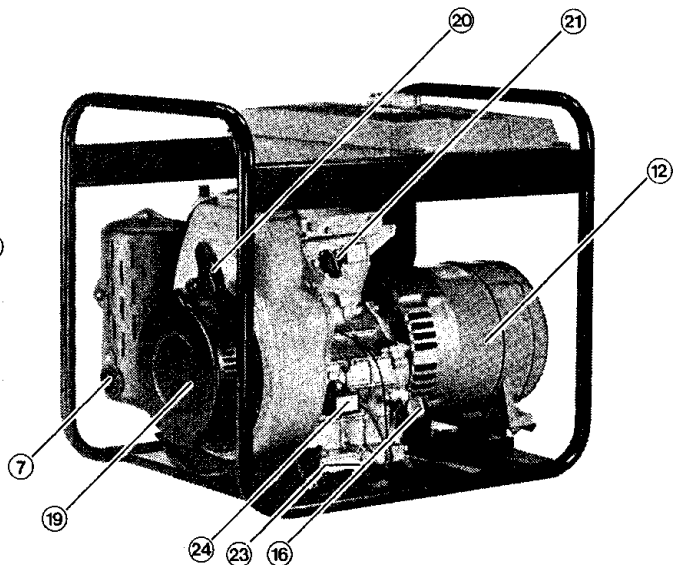
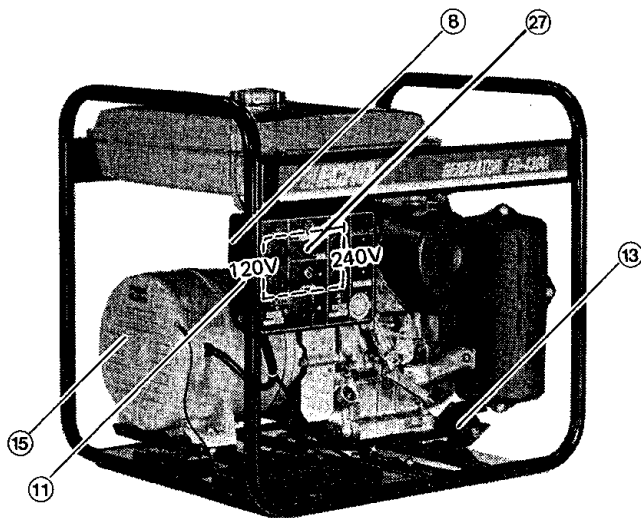
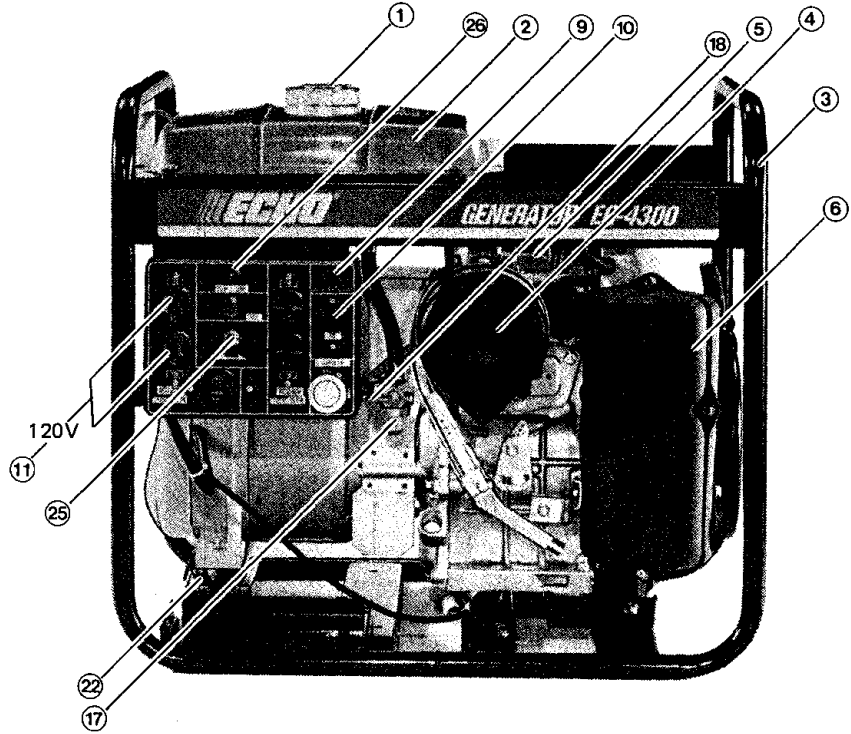

120V 240V

Learn Generator Safety

Improper use or maintenance by the operator can result in injury. Follow these safety suggestions.

Carefully read this manual. Learn how to operate your generator correctly. Also pay attention to point of use safety messages in this manual.

CAUTION:

Unauthorized modifications to the generator may impair the function and/or safety and affect machine life. Use only approved accessories on the generator.

DO NOT let anyone operate the generator without proper instruction.

PROTECT PEOPLE AND PETS

KEEP PEOPLE AND PETS OUT OF THE AREA where you are using the generator.

DO NOT let children operate the generator, or handle electrical power cords.

OPERATION OF A GENERATOR should be restricted to mature, properly instructed individuals.

HANDLE FUEL SAFELY-AVOID FIRES

DO NOT USE ANY OTHER FUEL than that recommended in your Owner's Manual. Handle gasoline with care: it is highly flammable. Use an approved gasoline container.

FILL THE FUEL TANK OUTDOORS.

DO NOT OVER FILL FUEL TANK. Fill fuel tank only to middle rib indicator in fuel filter insert.

DO NOT SMOKE while you fill fuel tank or service fuel system.

DO NOT REMOVE GAS CAP OR ADD GASOLINE to tank if engine is hot or running.

CLEAN UP spilled gasoline.

MOVE AWAY from refueling area before attempting to start generator engine.

KEEP ENGINE CLEAN. Remove grass, leaves excess oil and dirt before you start engine.

LET ENGINE COOL before you store generator in a building.

DO NOT store generator where fuel fumes could reach an open flame or spark.

Drain gasoline before transporting generator.

REFUEL IN A SAFE PLACE. Move the generator at least 10 feet from its operating location. Open the fuel cap slowly to release any pressure which may have formed in the fuel tank. Return the generator to its original location before re-starting the engine.

Safety Precautions

KEEP NUTS, BOLTS, AND SCREWS TIGHT. Loose parts may result in personal injury or damage to the unit.

DO NOT operate the generator without an air filter. **Rapide engine wear will result.**

DO NOT operate the generator if the oil level is low.

VENTILATING OPENINGS such as the generator cover, air filter and muffler exhaust outlet must be cleaned periodically and kept free of debris to ensure proper operation and adequate cooling of the generator.

SERVICE GENERATOR SAFELY

KEEP generator clean.

BEFORE you service or remove parts, let the engine cool.

DO NOT work on generator while it is being operated.

DO NOT adjust generator when engine is running, unless the procedure is approved. **STOP THE ENGINE.**

WAIT until generator is stopped before you service it.

USE ONLY identical replacement parts when servicing unit.

DO NOT ALTER EXHAUST SYSTEM Use only **ECHO** approved exhaust mufflers.

DO NOT ALTER ENGINE SETTINGS. The engine speed is controlled by a pre-set governor to deliver rated electrical power. Consult your **ECHO** servicing dealer if in doubt.

STORE GENERATOR SAFELY

Before you leave the generator unattended:

1. Stop engine by moving the Ignition Switch/Throttle Lever to the **STOP** position.
2. Turn fuel valve to **OFF** position.
3. Disconnect spark plug wire.
4. Do not store generator where fuel fumes could reach an open flame or spark.

WHEN NOT IN USE, STORE GENERATOR in a cool, dry place and **AWAY FROM POSSIBLE SOURCES** of ignition such as gas water heaters, furnaces, clothes dryers etc.

WHEN TRANSPORTING your generator, make sure it is in an upright position and that gasoline is not leaking. Secure it from sliding.

HAVE AN EXTINGUISHER NEARBY

Have a multipurpose dry chemical fire extinguisher filled and handy. Know how to use it.

COMPLY WITH ALL FIRE PREVENTION REGULATIONS. We recommend you keep a fire extinguisher and long-handle shovel close by whenever using a generator in areas where dry grass, leaves or other flammable materials are present.



Safety Precautions

RESPECT ELECTRICITY

DO NOT TOUCH ELECTRICAL EQUIPMENT while standing on metal floors, damp concrete, or other well-grounded surfaces.

DO NOT HANDLE ELECTRICAL EQUIPMENT while wearing damp, clothing (particularly wet shoes) or while skin surfaces are damp.

BE EXTRA CAUTIONS WHEN WORKING with generator during wet weather EG1500/2300/3500 & EG4300 Generators are not waterproofed. Using a generator in a wet place or during stormy weather could result in short circuits, electric shock or electrocution.

DO NOT examine equipment when mentally or physically stressed.

DO NOT WORK on ungrounded electrical equipment.

DO NOT CONNECT GENERATOR DIRECTLY to household electrical circuits.

DO NOT USE ungrounded extension cords.

NEVER ALTER CORD, or plug of any appliance to be used with generator.

⚠ WARNING:

These units produce 120V and model 3500, 4300 also produce 240V which may cause fatal electrical shock if above precautions are not followed.

USE ONLY POWER CORDS that are suitable for use outdoors and are so marked. Always examine power cords for signs of fraying, damage or cracks in the insulation before using them.

DO NOT HANDLE POWER CORDS that have damaged insulation or are wet.

DO NOT PLUG IN EXTENSION CORDS OR HOOK UP appliances until generator has been properly started, has reached full engine speed and is generating electricity.

DO NOT under any circumstances connect your generator to any circuit or receptacle receiving electrical power (home, office etc.) from any other sources as this is likely to result in a fire and damage to all electrical systems.

DO NOT, under any circumstances, use the generator for purpose that exceeds its rated capacity.

GROUND THE GENERATOR. The manufacturer has provided a grounding lug for the proper grounding of the generator. Manufacturer does not supply the required grounding conductor or grounding electrode because it would be impossible to cover every exception and meet all local code requirements. See your local code requirements for the proper grounding governing the use of your generator.

IF CONSIDERING CONNECTING GENERATOR to existing wiring systems (house, barn, pumps, for example), **CONTACT A LICENSED ELECTRICIAN** to ensure proper, safe connection and compliance with local electrical, fire safety and building codes.

INSPECT GENERATOR CAREFULLY

INSPECT THE GENERATOR CAREFULLY before you operate it.

GUARDS AND SHIELDS must be in place.

Safety Precautions

KEEP NUTS, BOLTS, AND SCREWS TIGHT. Loose parts may result in personal injury or damage to the unit.

DO NOT operate the generator without an air filter. **Rapide engine wear will result.**

DO NOT operate the generator if the oil level is low.

VENTILATING OPENINGS such as the generator cover, air filter and muffler exhaust outlet must be cleaned periodically and kept free of debris to ensure proper operation and adequate cooling of the generator.

SERVICE GENERATOR SAFELY

KEEP generator clean.

BEFORE you service or remove parts, let the engine cool.

DO NOT work on generator while it is being operated.

DO NOT adjust generator when engine is running, unless the procedure is approved. **STOP THE ENGINE.**

WAIT until generator is stopped before you service it.

USE ONLY identical replacement parts when servicing unit.

DO NOT ALTER EXHAUST SYSTEM Use only **ECHO** approved exhaust mufflers.

DO NOT ALTER ENGINE SETTINGS. The engine speed is controlled by a pre-set governor to deliver rated electrical power. Consult your **ECHO** servicing dealer if in doubt.

STORE GENERATOR SAFELY

Before you leave the generator unattended:

1. Stop engine by moving the Ignition Switch/Throttle Lever to the **STOP** position.
2. Turn fuel valve to **OFF** position.
3. Disconnect spark plug wire.
4. Do not store generator where fuel fumes could reach an open flame or spark.

WHEN NOT IN USE, STORE GENERATOR in a cool, dry place and **AWAY FROM POSSIBLE SOURCES** of ignition such as gas water heaters, furnaces, clothes dryers etc.

WHEN TRANSPORTING your generator, make sure it is in an upright position and that gasoline is not leaking. Secure it from sliding.

HAVE AN EXTINGUISHER NEARBY

Have a multipurpose dry chemical fire extinguisher filled and handy. Know how to use it.

COMPLY WITH ALL FIRE PREVENTION REGULATIONS. We recommend you keep a fire extinguisher and long-handle shovel close by whenever using a generator in areas where dry grass, leaves or other flammable materials are present.

PERSONAL PRECAUTIONS WHEN CHARGING BATTERIES

Someone should be within range of your voice or close enough to come to your aid when you work near a lead-acid battery.

Have plenty of fresh water and soap nearby in case battery acid contacts skin, clothing, or eyes.

Wear complete eye protection and clothing protection. Avoid touching eyes while working near battery.

If battery acid contacts skin or clothing, wash immediately with soap and water. If acid enters eye, immediately flood eye with running cold water for at least 10 minutes and get medical attention immediately.

NEVER smoke or allow a spark or flame in vicinity of battery or engine.

RISK OF EXPLOSIVE GASES

Working in the vicinity of a lead-acid battery is dangerous. Batteries generate explosive gases during normal battery operation. For this reason, it is of utmost importance that each time before using your generator to charge a battery, you read and follow the instruction exactly in this manual, those published by battery manufacturer and manufacturer of any equipment you intend to use in the vicinity of battery. Review cautionary marking on these products and engine.

Be extra cautious to reduce risk of dropping metal tool onto battery, it might spark or short-circuit battery or other electrical part that may cause explosion.

Remove personal metal items such as rings, bracelets, necklaces, and watches when working with a lead-acid battery. A lead-acid battery can produce a short-circuit current high enough to weld a ring or the like to metal, causing a severe burn.

⚠ WARNING:

Use generator for charging a **LEAD-ACID** battery only. Do not use battery charger for charging dry-cell batteries that are commonly used with home appliances. These batteries may burst and cause injury to persons and damage to property.

NEVER charge a frozen battery.

USING GENERATOR AS BOOSTER

⚠ WARNING:

Do not use generator to boost or jump start a vehicle as serious damage can result to generator and vehicle electrical system.

Safety Precautions

PREPARING TO CHARGE

If necessary to remove battery from vehicle to charge, always remove grounded terminal from battery first. Make sure all accessories in the vehicle are off, so as not to cause an arc.

Be sure area around battery is well ventilated while battery is being charged. Gas can be forcefully blown away by using a piece of cardboard or other nonmetallic material as a fan.

Clean battery terminals. Be careful to keep corrosion from coming in contact with eyes.

Add distilled water in each cell until battery acid reaches level specified by battery manufacturer. This helps purge excessive gas from cells. Do not overfill. For a battery without cell caps, carefully follow manufacturer's recharging instructions.

Study all battery manufacturer's specific precautions such as removing or not removing cell caps while charging and recommended rates of charge.

CHARGING BATTERY INSTALLED IN VEHICLE

Position battery charging supply cord to reduce risk of damage by hood, door, or moving engine parts.

Stay clear of fan blades, belts, pulleys and other parts that can cause injury to persons.

Never charge marine (boat) batteries on board. Charging marine batteries requires special equipment.

Never attach battery charging supply cord to grounded battery terminal, always connect to frame or engine block.

Never attach grounding battery charging supply cord to carburetor, fuel lines or sheet metal body parts.

Connect the positive battery terminal to the positive generator supply cable. Do not reverse the charging cables or serious damage to the generator and/or battery may occur.

⚠ WARNING:

To prevent the possibility of creating a spark near the battery, connect charging supply cables first to the battery, then plug them into the generator and disconnect cables at the generator first.

Unplug battery charging supply cord from generator before removing clamps from battery.

CHARGING BATTERY REMOVED FROM VEHICLE

Attach at least a 24-in. long (610mm) long 6-gauge (AWG) insulated cable to **NEGATIVE** battery post.

Position yourself and free end of cable as far away from battery as possible, then connect **NEGATIVE (BLACK)** clamp of battery charging supply cord to free end of cable.

Connect the positive battery terminal to the positive generator supply cable. Do not reverse the charging cables or serious damage to the generator and/or battery may occur.

Remove battery charging supply cord from generator before removing clamps from battery.

⚠ WARNING:

To prevent the possibility of creating a spark near the battery, connect charging supply cables first to the battery, then plug them into the generator and disconnect cables at the generator first.

Engine Oil

IMPORTANT:

Before starting engine for first time, add oil as unit is shipped dry.

Engine oil is a major factor affecting engine performance and service life. Non-detergent or vegetable oils are not recommended. Be sure to check the engine oil on a level surface with the engine stopped.

IMPORTANT:

Use premium quality engine oils meeting minimum performance requirements of API Service Classification SE or SF.

Quality engine oils are blended, so additives are neither required nor recommended.

LUBRICATION CHART			
SEASON	TEMPERATURES	OIL	
		SAE	API
Summer	Above 30°C Above 86°F	SAE 30	SE
	20° to 29°C 68° to 85°F	SAE 30	
Spring	10° to 19°C 44° to 67°F	SAE 20 or 10W-30	SF
Winter	Below 10°C Below 44°F	SAE 10 or 10W-30	

NOTE:

Engine oil should be changed after the first 20 hours of operation considered the breaking in period for your unit. Engine oil should be changed after every 50 hours of operation following the break in period. Always change the crankcase oil when the engine is warm for complete drainage.

Check the crankcase oil level frequently. Make sure the oil crankcase is full before starting the generator. Always check the crankcase oil level each time the fuel tank is refilled.

EG-1500	EG-2300	EG-3500	EG-4300
U.S. fl.oz. 15.2	U.S. fl.oz. 18.6	U.S. fl.oz. 32.1	U.S. fl.oz. 42.3
liters .45	liters .55	liters .95	liters 1.25

CAUTION:

Operating a generator with a low oil level will cause serious engine damage.

Fuel

Handle fuel carefully. If the engine is hot or running, do not fill the fuel tank. Do not smoke while you fill the fuel tank or service the fuel system. Fill fuel tank only to middle rib of fuel filter insert.

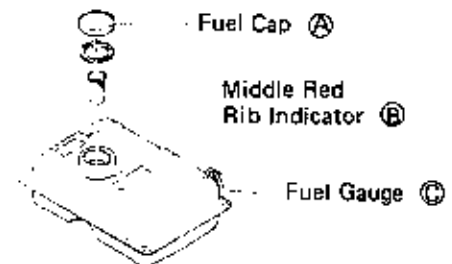

IMPORTANT:

DO NOT use gasoline-alcohol mixtures, such as gasohol or ethynol-blend gasoline. **DO NOT** mix oil with gasoline.

1. Use unleaded or regular automotive gasoline. Do not use gasoline that has been stored for a long period of time. (30 days maximum) Use gasoline with 87 to 92 octane rating.
2. Remove fuel cap (A) and fill only to middle rib indicator (B) in fuel filter insert.
3. Level seeking fuel gauge (C) indicates approximate fuel level in tank. Refill when needed.

CAUTION:

Fuel additives or special starting fluids should not be used because seals and other rubber composition parts may be damaged.



Fuels and Lubricants

SERVICING SET UP OF NEW UNIT OR CHANGING ENGINE OIL

IMPORTANT:

Before starting engine for first time, add oil as unit is shipped dry.

NOTE:

Change engine oil after first 20 hours of operation and every 50 hours thereafter.

1. Set generator on level surface.
2. Run engine a few minutes to warm oil.
3. Stop engine.
4. Remove oil dipstick(A) and oil drain plug(B). Drain oil into container. Don't pollute, dispose of waste oil properly. (SEE PHOTO IN NEXT PAGE)
5. Install oil drain plug and tighten.
6. Add oil. (See Lubricants section for correct oil.)

ENGINE OIL CAPACITY

Model	U.S. fl.oz	liters
EG1500	15.2	0.45
EG2300	18.6	0.55
EG3500	32.1	0.95
EG4300	42.3	1.25

7. Install dip stick and thread into place.
8. Remove dipstick to check oil level.
9. Add oil if necessary.
10. Check O-ring placement and condition on dipstick before installing.

NOTE:

Checking engine oil level see General Maintenance section.

11. Install and tighten dipstick.

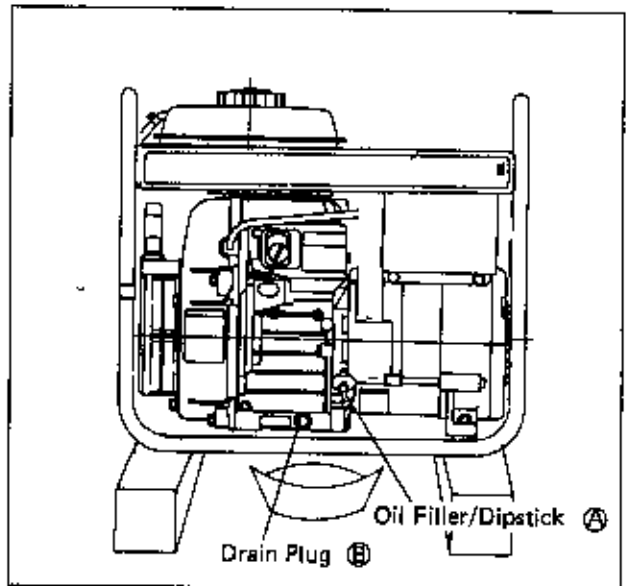

- A. Mount unit on cement or wooden blocks about 6 inches high.
- B. Remove oil drain plug (B) on rear bottom of unit. Place drain pan under unit.
- C. Remove oil dipstick (A) to break vacuum air seal.
- D. Reinstall oil drain plug (B).
- E. Add engine oil.

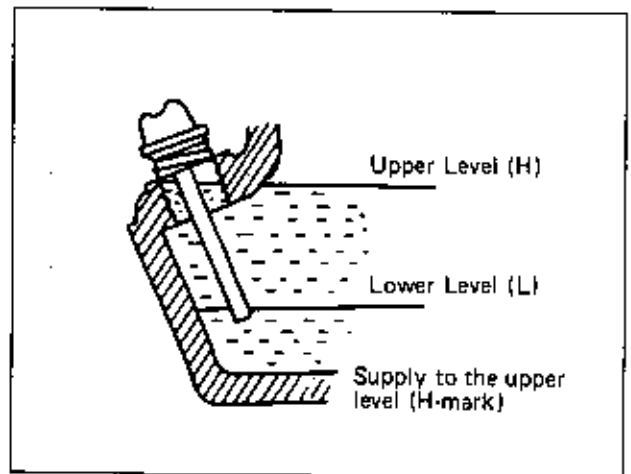

Engine Oil Level

Wattage Calculating Instructions

CALCULATING WATTAGE REQUIREMENTS (AC)

IMPORTANT:

These generators provide limited output for stand-by power installations. Do not exceed rated capacity of your generator.

Two types of electrical appliances may be powered by your generator:

- Resistive load devices such as light, heaters, TV sets, radios, hand held power tools, etc., and
- Inductive load devices, such as induction start motors.

The starting wattage required by resistive loads is the same as the running wattage needed to run the appliance. The starting wattage for inductive load appliance is higher than the appliances running wattage requirements. Maximum inductive starting load capacity, therefore, is smaller than the maximum resistive load capacity.

WARNING:

The starting wattage for inductive load appliances may be 3 to 3.5 times greater than the appliances running wattage requirements.

GENERATOR APPLICATION WORKSHEET			
Requirements	Running Wattage	Inductive Starting Wattage	Total Wattage
Lights	60	0	
Radio	80	0	
TV	255	0	
Total	395	0	395

IMPORTANT:

Do not exceed rated capacity of your generator. Serious damage to the generator or appliance can result.

Before operating the generator, perform the following exercise to determine what items or combinations of item the generator can power.

- List all light bulbs, appliances, and tools which will be operated.
- Fill in any running wattage of items listed and total the values.

NOTE:

Wattage can usually be found on light bulbs or appliance name plate. If not, determine wattage by multiplying listed amperage by voltage.

$$\text{Volts} \times \text{Amps} = \text{Watts.}$$

Use actual wattage values, if available.

If not, use the values in the following charts as a guide.

There are example of appliances in the charts that are over the rated generator capacities. These are being shown for reference data only. The running and inductive starting wattages shown in these charts are approximations.

WATTS REQUIRED TO START MOTOR				
Motor Size (HP)	Running Watts	Repulsion Induction	Capacitor	Split Phase
1/8	275	600	850	2050
1/4	400	850	1050	2400
1/3	450	975	1350	2700
1/2	600	1300	1800	3600
3/4	850	1900	2600	-
1	1100	2500	3300	-

NOTE:

Operating generators with simultaneous AC and DC loading is not recommended. (Model EG1500, EG2300)

- If inductive starting wattage is less than generator capacity, running and inductive starting wattages do not have to be totaled.

IMPORTANT:

Total running wattage must be less than generator capacity. Total inductive starting wattage must be less than generator capacity.

GENERATOR APPLICATION WORKSHEET			
Requirements	Running Wattage	Inductive Starting Wattage	Total Wattage
Furnace "1/8"HP	300	500	
Total	300	500	

Wattage Calculating Instructions

4. Using figures calculated, use chart to compare requirements to generator capacity.

If generator capacities are not adequate to cover all requirements, deduct the least needed appliance so generator can be used without overloading.

If requirements are mandatory and cannot be reduced, obtain a larger capacity generator.

$$\text{Volts} \times \text{Ampere} = \text{Watts}$$

GENERATOR CAPACITY CHART			
Model EG	Continuous Running Wattage Capacity	Maximum Running Wattage Capacity	Maximum Inductive Starting Wattage Capacity
1500	1300	1450	650
2300	2000	2200	1000
3500	3050	3300	1500
4300	3800	4300	1900

EXTENSION CORD USAGE

When using a tool at a considerable distance from power source, a 3-conductor, grounding-type extension cord of adequate size must be used for safety, and to prevent loss of power and overheating. Use the table below to determine the minimum wire size required.

NOTE:

Use only three wire extension cords which a three-prong grounding type plugs and three-pole receptacles which accept the tool's plug. Replace or repair damaged cords immediately.

CAUTION:

A cord that is hot to the touch is overloaded.

Wire Gauge Chart

EXTENSION CABLE LENGTH	EG1500	EG2300	EG3500	EG4300
	110V	110V	120V/240V	
25 Ft. (7.62M)	16	12	10	
50 Ft. (15.24M)	16	12	10	
75 Ft. (22.86M)	14	12	10	
100 Ft. (30.48M)	12	10	8	
150 Ft. (45.27M)	12	8	8	
200 Ft. (60.94M)	10	8	8	

American Wire Gauge Size

MAXIMUM OUTPUT OPERATION

Limit operation of the generator at maximum output to 30 minutes. Additional 3 minutes periods of maximum output are possible if the generator is allowed a 10 minutes to cool between periods of maximum output. Cool engine by operating in the throttle position with the output load disconnected.

* Will Operate

General Application Guide for EG-1500 ~ EG-4300

ITEMS	WATTS	EG1500	EG2300	EG3500	EG4300
RADIO	50	*	*	*	*
12 VOLT DC BATTERY	100	*	*	*	*
LIGHT BULB	100	*	*	*	*
BLANKET	150	*	*	*	*
SLOW COOKER	200	*	*	*	*
WINDOW FAN	250	*	*	*	*
DRILL (1/4")	250	*	*	*	*
DRILL (3/8")	500	*	*	*	*
TELEVISION (COLOR)	300	*	*	*	*
SUMP PUMP	400	*	*	*	*
DEEP FREEZER	500	*	*	*	*
BELT SANDER	600	*	*	*	*
REFRIGERATOR	600	*	*	*	*
MICROWAVE OVEN	700	*	*	*	*
FURNACE FAN (1/4HP)	800	*	*	*	*
COFFEE MAKER	850	*	*	*	*
CIRCULAR SAW (6-1/2")	1000	*	*	*	*
EDGER	1100	*	*	*	*
TOASTER	1100	*	*	*	*
CIRCULAR SAW (7-1/2")	1200	*	*	*	*
RANGE (1 element)	1200	*	*	*	*
DISC SANDER	1200	*	*	*	*
FURNACE FAN (1/3HP)	1200	*	*	*	*
ELECTRIC CHAIN SAW	1200	*	*	*	*
RADIANT HEATER	1300	*	*	*	*
AIR CONDITIONER (12,000 BTU)	1700	*	*	*	*
COMPRESSOR (3/4HP)	2000	*	*	*	*
SUBMERSIBLE PUMP (1 HP)	2000	*	*	*	*
BARN CLEANER	2500	*	*	*	*
SILAGE UNLOADER	2500	*	*	*	*
WATER HEATER	3000	*	*	*	*

Watts : Running Watts

Wattage Calculating Instructions

Miscellaneous wattage requirement

REQUIREMENTS	TOTAL Inductive Starting Watts
Air Condition, Central 20,000 BTU 24,000 BTU	5,800 8,750
Blanket, Electric	400
Charger, Battery 4 amp 10 amp 15 amp 30 amp w/200 amp boost 60 amp w/250 amp boost	90 200 380 650/3,800 1,500/5,750
Cleaner, Grain 1/4 HP	1,650
Coffee Maker	1,750
Compressor, Air 1/2 HP 1 HP	3,000 6,000
Conveyor, Portable 1/2 HP	3,400
Cooler, Milk	2,900
Cultivator, Electric	2,100
Dehumidifier	1,450
De-Icer, Stock Tank	1,000
Dish Washer Cool dry Hot dry	2,100 1,000
Drill, Hand 1/4 inch 3/8 inch 1/2 inch	350 400 800
Dryer, Clothes Gas Electric	2,500 7,550
Dryer, Hair	300 - 1,200
Elevator, Grain 3/4 HP	- 4,400
Fence, Electric (25 mHa) Freezer Frypan, Electric	250 2,900 1,300
Furnace Fan (Gas or Fuel Oil) 1/8 HP 1/6 HP 1/4 HP 1/3 HP 1/2 HP	800 1,250 1,800 2,100 3,225

REQUIREMENTS	TOTAL Inductive Starting Watts
Grinder, Bench 6 inch 8 inch	1,720 3,900
Heater, Portable Space (Kerosene, Diesel Fuel) 30,000 BTU 50,000 BTU 85,000 BTU 90,000 BTU 140,000 BTU 160,000 BTU 350,000 BTU	800 1,000 1,225 1,225 1,625 1,625 2,125
Iron	1,200
Light Bulbs	Indicated on Bulb
Lights, Flood HID Metal Halide Mercury Vapor (Not recommended) Sodium Vapor	125 313 — 1,250
Mixer (Vacuum Pump) 2 HP	10,500
Milker 3-1/2 cu. ft 1/2 HP	3,300
Mixer, 55 gal. drum 1/4 HP	1,900
Motors, Farm Duty Standard (e.g. conveyor, feed auger, air compressor) 1/3 HP 1/2 HP 3/4 HP	1,720 2,575 4,500
High Torque (e.g. barn leaners, silo unloaders, silo hoists, bunk feeders) 1-1/2 HP	8,100
Motors, Industrial Duty Split Phase 1/8 HP 1/6 HP 1/4 HP 1/3 HP	800 1,225 1,600 2,100
Capacitor Start Induction Run 1/3 HP 1/2 HP 3/4 HP	2,020 3,075 4,500
Capacitor Start Capacitor Run 1-1/2 HP	8,100

Wattage Calculating Instructions

Miscellaneous wattage requirement

REQUIREMENTS	TOTAL Inductive Starting Watts
Fan Duty 1/8 HP 1/6 HP 1/4 HP 1/3 HP 1/2 HP	1,000 1,400 1,850 2,400 3,500
Opener, Garage Door 1/4 HP 1/3 HP Oven, Microwave (625-watt)	1,650 9,225 2,800
Polisher, Floor 16 inch - 3/4 HP 20 inch - 1 HP	4,600 6,100
Pumps Centrifugal, 900 GPH Submersible, 400 GPH Sump 1/3 HP 1/2 HP Wet 1/3 HP 1/2 HP	900 600 2,100 3,200 2,150 3,100
Radio	50 - 200
Refrigerator	2,900
Saws Bark, 14 inch Circular, 6 - 1/2 inch 7 - 1/4 inch 8 - 1/4 inch	2,500 500 900 1,400
Electric chain 1/2 inch, 1-1/2 HP 14 inch, 2 HP	900 1,100

REQUIREMENTS	TOTAL Inductive Starting Watts
Table 9 inch 10 inch	4,500 6,300
Television Color Black and White	300 100
Toaster 2 Slice 4 Slice	1,050 1,850
Trimmer, Hedge 18 inch	400
Trimmer, Nylon Line Standard 9 inch Heavy Duty 12 inch	350 500
Vacuum Cleaner Standard Deluxe	800 1,100
Vacuum, Wet & Dry 1.7 HP 2.5 HP	900 1,300
Washer, Clothes	3,450
Washer, High-Pressure 5/8 HP 1 HP 1-1/2 HP	4,600 9,050 10,310
Welder 70 amp 100 amp 200 amp	2,000 3,600 9,000

IMPORTANT:

There are examples of appliances in this chart that are more than rated generator capacities. They are shown for reference data only. The running and additional inductive starting wattage shown in this chart are approximations. Actual wattage can usually be found on light bulbs or appliance name plate. If not, determine wattage by multiplying listed amperage by voltage.

Prestarting Information

1. GROUNDING GENERATOR

The National Electrical Code (NEC) requires that all separately derived AC systems be grounded per Article 250-26. Manufacturer has added a grounding lug type terminal per Article 250-26 (a) from the non-current-carrying metal parts to the conductor to be grounded. Manufacturer does not supply the required grounding conductor or grounding electrode because it would be impossible to cover every exception and all local code requirements. See your local codes and the NEC manual for the proper grounding for your application.

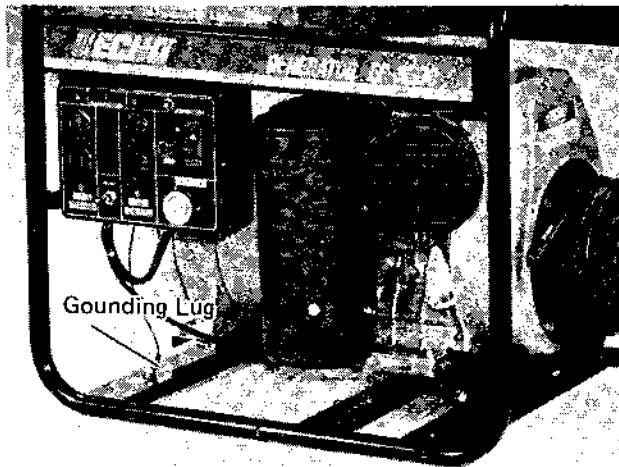

Location of grounding lug type terminal

NOTE:

- * As a general rule, do not use electrical equipment in wet or damp areas. Additional rules from NEC, OSHA and state codes apply to portable generators when used on construction sites.
- * It is the responsibility of the consumer to meet the above requirements.

CAUTION:

The generator must be placed on a firm, level surface for proper lubrication of the engine.

2. POWER INDICATOR PILOT LIGHT

Power indicator light(A) is bright amber at full power and dim or flickering when engine is idling, during AC or DC operation.

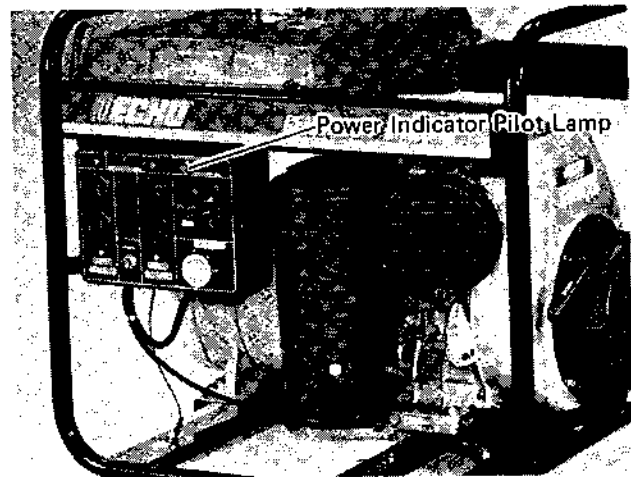

Location of Power Indicator Pilot Light

3. AC RECEPTACLES—CIRCUIT BREAKER—FUSE —ALL MODELS—

IMPORTANT:

Do not exceed rated capacity of your generator, as serious damage to the generator or appliance could result.

Do not start engine under load, i.e., when appliance is connected.

3-1 CONNECTING 120 V RECEPTACLES — ALL MODELS —

IMPORTANT:

Note receptacle wiring polarity to prevent equipment or generator failure.

Plug connections to all equipment should be as follows:

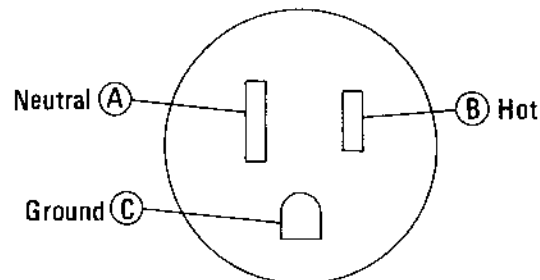

Prestarting Information

3-2 CONNECTING 240 V RECEPTACLES MODELS EG-3500/EG-4300

IMPORTANT:

Note receptacle wiring polarity to prevent equipment or generator failure.

Plug connections to all equipment should be as follows:

- (A) Neutral
- (B) Hot
- (C) Ground

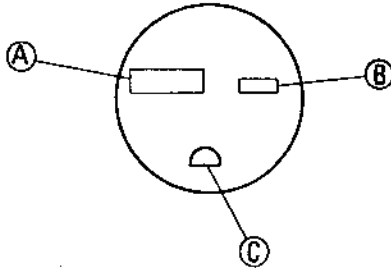

3-3 CONNECTING 12 VDC RECEPTACLE MODEL EG-1500 - EG2300

IMPORTANT:

Note receptacle wiring polarity to prevent equipment or generator failure.

Plug connections to all equipment should be as follows:

- (A) Positive ⊕
- (B) Negative ⊖

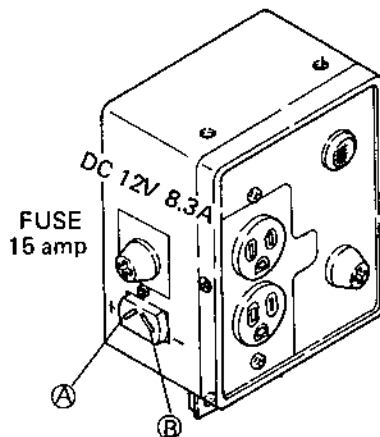

NOTE:

Fuse will "blow" under circuit overload condition. When a fuse "blows", determine the cause. Typical causes are excessive loading or electrical system shorting. If a fuse "blows" stop the engine, locate and correct the problem. Using a Phillips screw driver, unscrew fuse holder and inspect fuse for broken/melted element.

3-4 MAXIMUM OUTPUT OPERATION

Only operate generator at maximum output for 3 minutes. Allow generator to cool for 10 minutes before operating again. Cool generator by operating engine at maximum rpm with all loads disconnected.

4. AC RECEPTACLES/CIRCUIT BREAKER/ FUSE - EACH MODELS -

4-1 AC RECEPTACLES AND FUSE MODEL EG-1500 - 120VAC

Rated continuous duty 1300 watts/maximum 1450 watts (3 minutes)

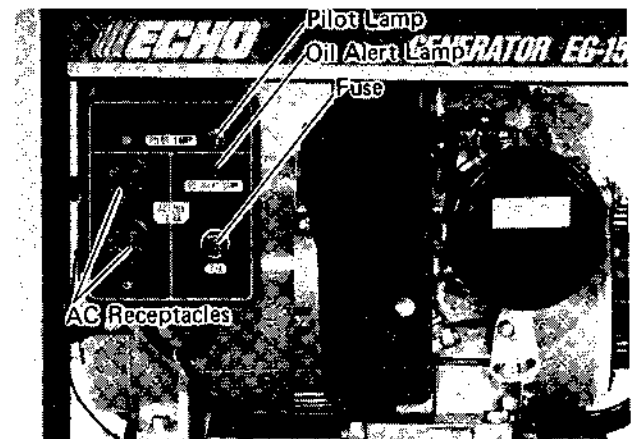

IMPORTANT:

Do not exceed maximum rated capacity of your generator, as serious damage to the generator or appliance could result.

Disconnect appliances from generator before starting engine.

The generator is equipped with two frame grounded 120-V 10.8 amps total draw AC receptacles (A).

The receptacles are protected by one 12 amp fuse.

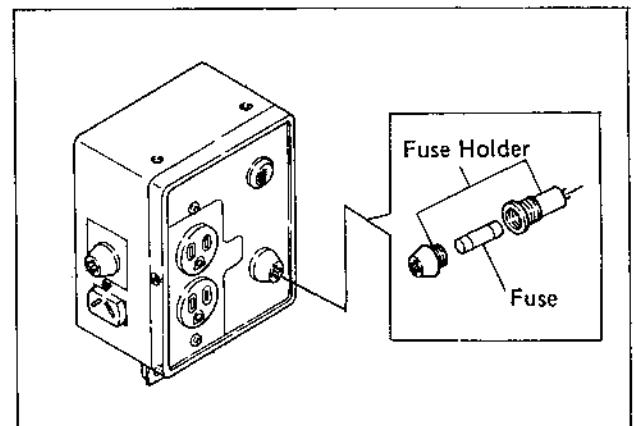

NOTE:

The fuse will blow under circuit overload conditions. When a fuse blows, determine the cause. Typical causes are excessive loading or electrical system shorting. If a fuse blows, stop the engine and locate and correct the problem. Using a Phillips screw driver remove the fuse holder and inspect the fuse for broken/melted elements.

WARNING:

Replace the fuse with 12 amp fuse only. Inserting improperly rated fuse will damage generator equipment and void warranty.

NOTE:

MAXIMUM OUTPUT OPERATION - Only operate generator at maximum output for three minutes. Allow generator to cool for 10 minutes before operating again. Cool generator by operating engine at maximum rpm with all loads disconnected.

4-2 AC RECEPTACLES AND CIRCUIT BREAKER MODEL EG-2300 120VAC

Rated continuous duty 2000 watts/maximum 2200 watts (3 minutes).

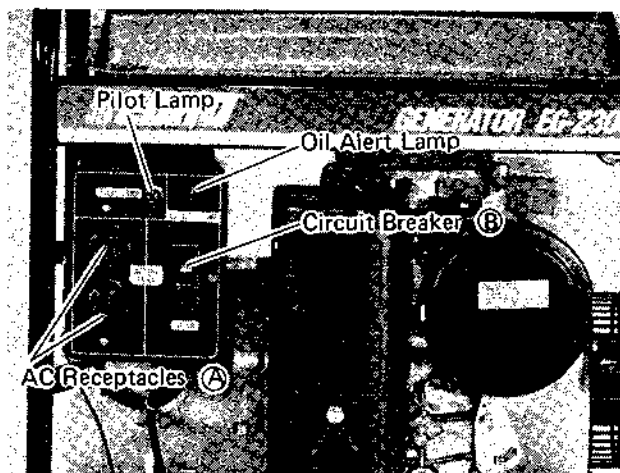
IMPORTANT:

Do not exceed maximum rated capacity of your generator, as serious damage to the generator or appliance could result.

Disconnect appliances from generator before starting engine.

The generator is equipped with two frame grounded 120V 16.6 amp total draw AC receptacles (A).

The receptacles are protected by one 17 amp switch type circuit breaker (B).

NOTE:

Circuit breakers trip automatically under circuit overload. When a circuit breaker trips, determine the cause. Typical causes are excessive loading or electrical system shorting.

If a circuit breaker trips, located and correct the problem, and allow circuit breaker to cool for 1 minute. Then reset circuit breaker by moving switch to "ON".

NOTE:

Do not attempt to plug 240 volt equipment into the 120 volt receptacles as serious damage to generator or appliance could result.

4-3 AC RECEPTACLES/CIRCUIT BREAKER/FUSE MODELS EG-3500 - EG-4300 - 120 V/240 VAC

Rated Continuous Duty 3050 Watts/Maximum/3300 Watts (3 Minutes) for EG-3500

Rated continuous Duty 3800 Watts/maximum/4300 Watts (3 Minutes) for EG-4300

IMPORTANT:

Do not exceed maximum rated capacity of your generator, as serious damage to the generator or appliance could result.

Disconnect appliances from generator before starting engine.

The generator is equipped with two frame grounded 120V 25 amp for EG-3500 or 3 frame grounded 120V 31.7amp for EG-4300 total draw AC receptacle (A) and two frame grounded 240V 12.5 amp for EG-3500 or 240V 15.8amp for EG-4300 total draw AC receptacle (B).

The receptacles are protected by one 15 amp for EG-3500 or 20 amp for EG-4300 switch-type circuit breaker (C) and one 15 amp fuse (D).

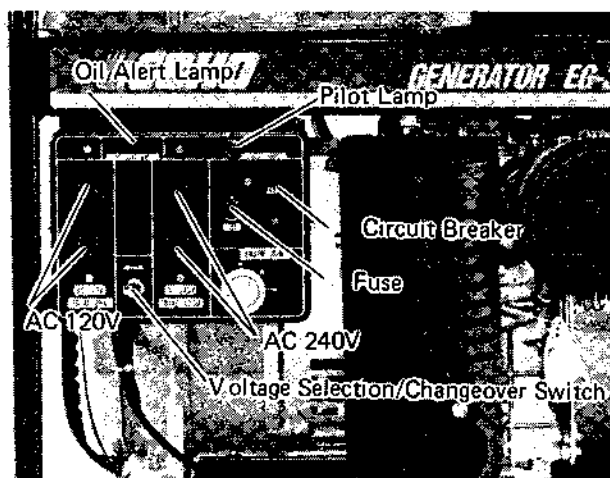

Prestarting Information

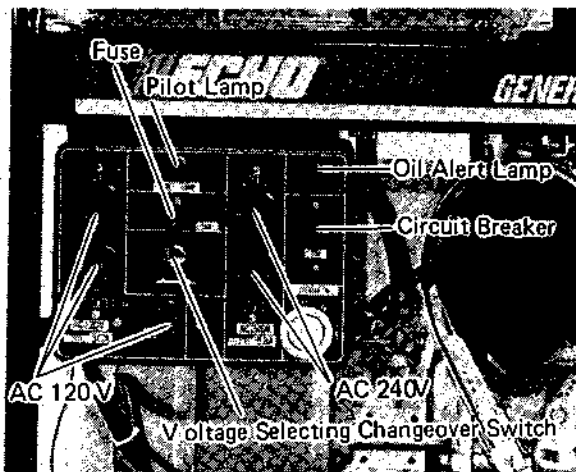

NOTE:

Circuit breakers trip automatically under circuit overload. When a circuit breaker trips, determine the cause. Typical causes are excessive loading or electrical system shorting.

If a circuit breaker trips, locate and correct the problem, and allow circuit breaker to cool for 1 minute. Then reset circuit breaker by moving switch to "ON".

NOTE:

Fuse will blow under circuit overload condition. When a fuse blows, determine the cause. Typical causes are excessive loading or electrical system shorting. If a fuse blows, stop the engine, locate and correct the problem. Using a Phillips screw driver, unscrew the fuse holder and inspect fuse for broken/melted element.

WARNING:

Replace fuse with 15 amp for EG-3500 or 20 amp for EG-4300 fuse only. Inserting improperly rated fuse will damage the generator, equipment, and will void warranty.

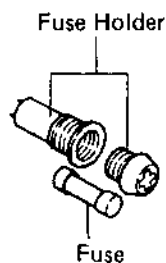

5. VOLTAGE SELECTING/CHANGEOVER SWITCH — Models EG-3500/EG4300 —

This generator will supply 120V or 240V output. The left hand receptacles supply 120 volts and the right hand receptacles supply 240 volts.

WARNING:

Do not attempt to plug 240 volt equipment into a 120 volt receptacle or 120 volt equipment into a 240 volt receptacle on the generator, as serious damage to the generator or appliance could result.

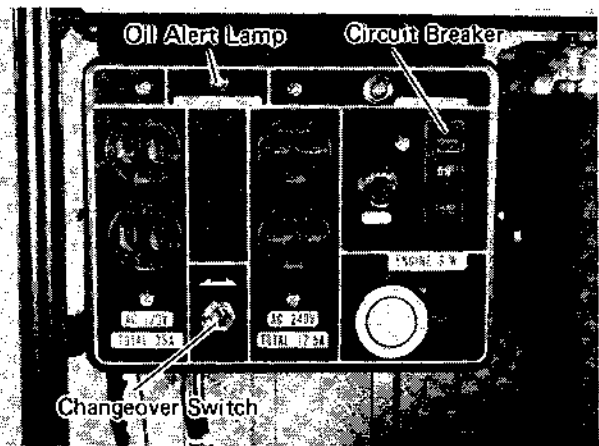

CAUTION:

Make sure that the voltage selecting/changeover switch is in the correct position for voltage being used, serious damage to generator or appliance could result if the switch is placed in the wrong position. The voltage selecting changeover switch must be in the left hand position when 120 volts receptacles are being used and in the right hand position when 240 volts receptacles are being used.

WARNING:

Do not operate the generator with 120 volts and 240 volts equipment connected simultaneously, serious damage to generator or appliance could result.

6. MAXIMUM OUTPUT OPERATION

Only operate generator at maximum output to 3 minutes. Allow generator to cool for 10 minutes before operating again. Cool generator by operating engine at maximum rpm with all loads disconnected.

NOTE:

When the circuit breaker is in the "ON" position, voltage selector changeover switch in the 240V right hand position and the 240 volts outputs not available, check for blown fuse.

Prestarting Information

7. OPERATING GENERATOR/AC OUTPUT — ALL MODELS —

1. Make sure all power tools, extension cords, appliances are disconnected from the generator.
2. Check that equipment switches are in the "OFF" position.
 - A) Model EG-2300, EG-3500, EG-4300 place generators circuit breakers switches in the "OFF" position.
3. Start engine (See Starting The Engine)
4. Set engine speed at maximum rpm by placing throttle lever at "RUN" position.

CAUTION:

Do not plug in extension cords to generator receptacles or attempt to operate electrical tools or appliances when engine is operating at idle or intermediate speed positions, as damage to generator or appliance could result.

5. Allow the engine to warm up 2 ~ 3 minutes before connecting tools or appliances.
6. Models EG-3500, EG-4300 set the voltage selecting/changeover switch. Left hand position for 120V use, right hand position for 240V use.
7. Connect equipment to generator receptacle.
8. Model EG-2300, EG-3500, EG-4300 — Turn "ON" AC circuit breaker switch.
9. The amber pilot light on the receptacle panel will be "ON" when generator is operating properly.

8. FREQUENCY (Hz)

Your generator has been factory preset to 60 cycles (one Hertz [Hz]) equals one cycle/per second, the same as 120 volt household current, at 3600rpm with throttle in FULL position, under load.

The 60 cycle output is the standard electrical frequency for the United States.

IMPORTANT:

Certain appliances should only be operated at specified frequencies, such as a clock, record player or tape recorder. Check with the operating instructions or date plate of the appliance.

NOTE:

Adjustment or changing of frequency should only be made by an authorized ECHOservicing dealer.

9. DC RECEPTACLES AND FUSE Models EG1500/EG-2300

Before attempting to use generator, check wattage requirement on nameplate of appliance to be operated. (See Calculating Wattage Requirements in this section.)

IMPORTANT:

Wattage requirements for equipment usage or battery charging must not exceed generator capacity.

Do not start engine under load, i.e. when appliance is connected.

Usable DC capacity is 12V at 8.3 amps or 100 watts. The generator is equipped with one 12 VDC receptacle and a battery charging supply cord. The DC receptacle circuit is protected by a 15 amp fuse.

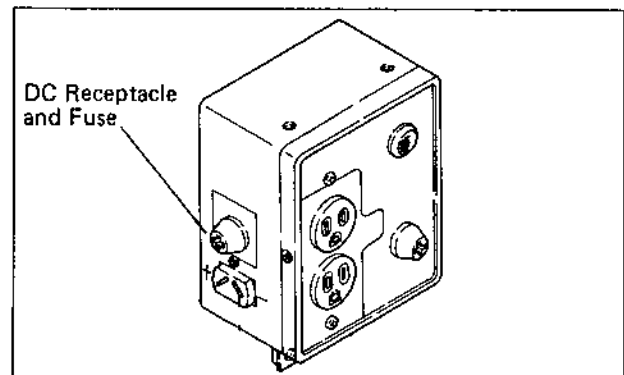

NOTE:

Fuse will "blow" under circuit overload condition. When a fuse "blows", determine the cause. Typical causes are excessive loading or electrical system shorting. If a fuse "blows" stop the engine, locate and correct the problem. Using a Phillips screw driver, unscrew fuse holder and inspect fuse for broken/melted element.

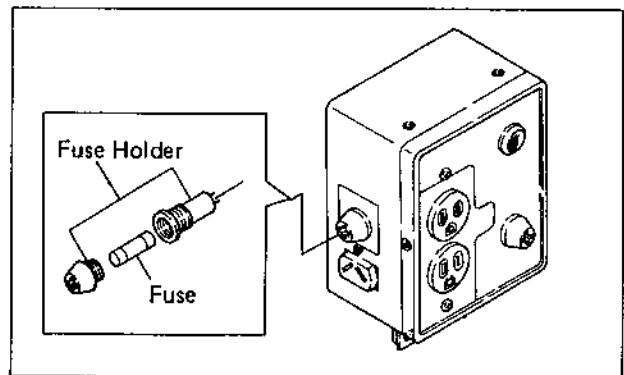

WARNING:

Replace fuse with 15 amp fuse only. Inserting improperly rated fuse will damage generator equipment, and voids warranty.

Prestarting Information



10. USING GENERATOR AS BOOSTER

⚠ WARNING:

Do not use generator to boost or jump start a vehicle as serious damage can result to generator and vehicle electrical system.

⚠ WARNING:

Use generator for charging a LEAD-ACID automotive type battery only. Do not use battery charger for charging dry-cell batteries that are commonly used with home appliances. These batteries may burst and cause injury to persons and damage to property.

NEVER charge a frozen battery.

📌 NOTE:

Using the generator DC output to charge an extremely discharged 12-volt battery may overload the circuit and blow the fuse.

11. OPERATING GENERATOR/DC OUTPUT

⚠ IMPORTANT:

Do not connect charging supply cables to battery while, engine is running.

To help prevent overheating of charging wire or cable when charging batteries, use 14 gauge (AWG) wire or larger.

📌 NOTE:

Larger wire will have (smaller AWG number.)

1. Connect charging leads to battery or equipment
(See **Connecting Generator to Battery or Equipment**)
2. Start generator engine.
(See **Starting Engine/Operating Engine Section.**)
3. Place throttle lever in "RUN" position.
4. Plug in battery charging supply cable to 12-VDC receptacles.
5. The amber pilot light on the receptacle panel will be "ON" when the generator is operating properly.

Charging Batteries

USING GENERATOR AS BOOSTER

❏ IMPORTANT:

Do not use generator to boost or jump start a vehicle as serious damage can result to generator and vehicle electrical system.

PREVENT BATTERY EXPLOSIONS

Battery gas can explode. Charge batteries in a well ventilated area. Keep sparks and flames away from batteries. Do not short across battery terminals. Do not lay tools on top of battery.

Always remove grounded (-) battery clamp first and replace it last.

AVOID ACID BURNS

Sulfuric acid battery electrolyte is poisonous. Even though it is diluted, it is strong enough to cause sight loss, burn skin, or damage clothing.

Fill new batteries in a well ventilated area, wear eye protection and rubber gloves, and avoid breathing any fumes from the battery when the electrolyte is added. Avoid spilling or dripping electrolyte when using a hydrometer to check specific gravity readings.

If acid gets in your eyes, flush them right away with large amounts of water, and see a doctor at once. If you spill acid on yourself, flush your skin immediately with lots of water. Apply baking soda or lime to help neutralize the acid.

PREPARE THE BATTERY

1. Before charging, make certain battery has enough electrolyte in each cell to cover top of plates.
2. If battery is equipped with vented caps, make certain they are properly installed.

❏ CAUTION:

Be careful to keep corrosion from coming in contact with eyes. Never smoke in vicinity of battery.

3. Clean battery terminals.

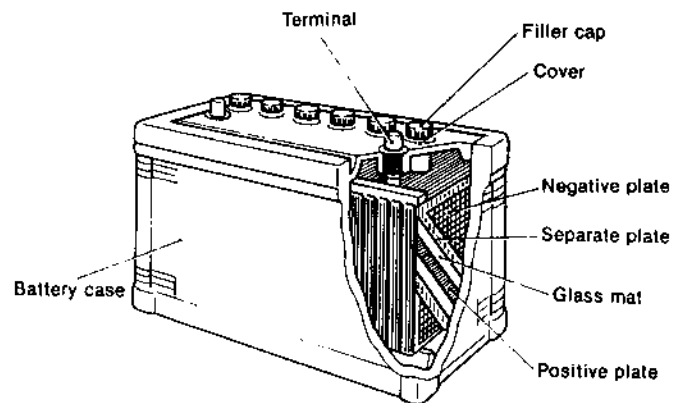

Charging Batteries

CHECK BATTERY SPECIFIC GRAVITY

Use a hydrometer (A) to determine state of charge. Refer to chart to obtain percent of charge.

Hydrometer reading Specific gravity	Battery test reading Percent of charge
1.260	100%
1.220	75%
1.180	50%
1.140	25%
1.100	0%

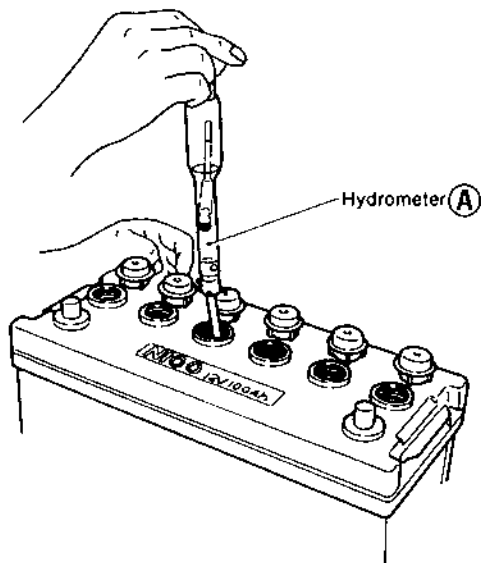

NOTE:

Any battery 25% charged or lower, may readily freeze and should be charged at once.

IMPORTANT:

If battery has just been charged, a surface charge may exist creating a false or higher than normal reading.

To eliminate surface charge, the battery must be discharged for 3 to 5 minutes by creating a load such as turning lights on.

CONNECTING GENERATOR TO BATTERY OR EQUIPMENT

CAUTION:

Never charge marine batteries on board. Do not physically touch battery charging leads, battery terminals, or equipment simultaneously. Injury can result from electrical shock. Do not allow charging leads to contact each other or vehicle. Sparks could ignite gases and cause an explosion. Do not connect **NEGATIVE** charging lead to carburetor or fuel lines.

1. Connect **POSITIVE** generator charging lead to the **POSITIVE(+)** battery terminal or the **POSITIVE (+)** equipment terminal.

IMPORTANT:

Make certain to check vehicle to determine if electrical system is positive or negative grounded. Connect clamps accordingly.

- 2a. If battery is not installed in the vehicle attach at least a 610 mm (24 in.) long G-gauge (AWG) insulated battery cable to **NEGATIVE (-)** battery terminal. Connect **NEGATIVE** generator charging lead to end of insulated battery cable attached above.
- 2b. If battery is installed in the vehicle, attach **NEGATIVE** generator charging lead to clean, well grounded area on the chassis away from battery.

IMPORTANT:

If sparking occurs between battery charging supply cord clamps and battery posts or the battery charging supply cord plug, disconnect battery charging supply cord from generator immediately; clamps or battery charging supply cord is being connected to wrong battery posts or terminals. Check battery and wiring to correctly identify **POSITIVE** and **NEGATIVE** battery post.

3. Start generator engine. Set throttle lever to "**FULL**" run position and allow engine to warm up.
4. Plug in battery charging supply cord into 12 volt DC receptacle.

STOPPING AND DISCONNECT GENERATOR FROM BATTERY OR EQUIPMENT

CAUTION:

Do not remove charging leads from battery terminals while generator is operating. Sparks could ignite gases and cause an explosion.

1. Stop engine
2. Disconnect generator charging leads from battery.
3. Disconnect charging leads from generator.

CHARGING TIME

IMPORTANT:

Do not leave generator on battery for indefinite long periods. Overcharging will boil electrolyte and can damage battery.

Charging Batteries

The charging rate will be dependant on the internal condition (percent of charge) and size of the battery. A very cold battery, one that is sulfated or larger batteries charge at slower rates.

After charging battery, use a hydrometer (A) to determine the specific gravity. Refer to "Check Battery Special Gravity" in this section.

If higher percent of charge is desirable, put the generator back on the battery until desired level is reached.

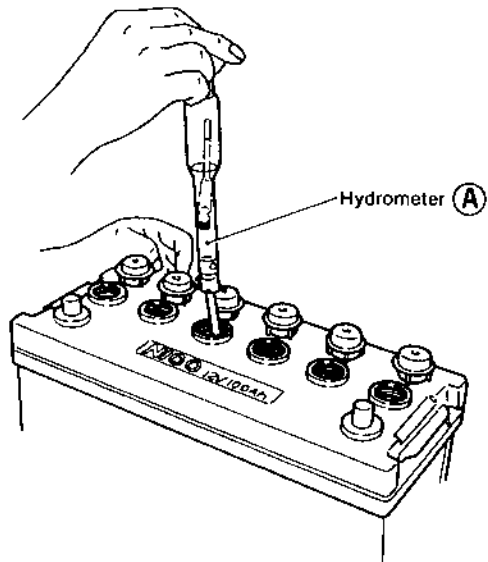

Prestart Checks and Operating The Engine

Starting the Engine

CAUTION:

Do not run engine in an enclosed area. Exhaust gas contain carbon monoxide, an odorless and deadly poison.

CAUTION:

Do not start engine with AC or DC loads connected damage to the generator or appliance may result.

IMPORTANT:

Before starting engine for first time, add oil as unit is shipped dry. (See Changing Engine Oil in Service/50 Hours) (Breaking in after first 20 hrs.)

1. Check engine oil level before each use.
2. Never check or add oil while engine is running.

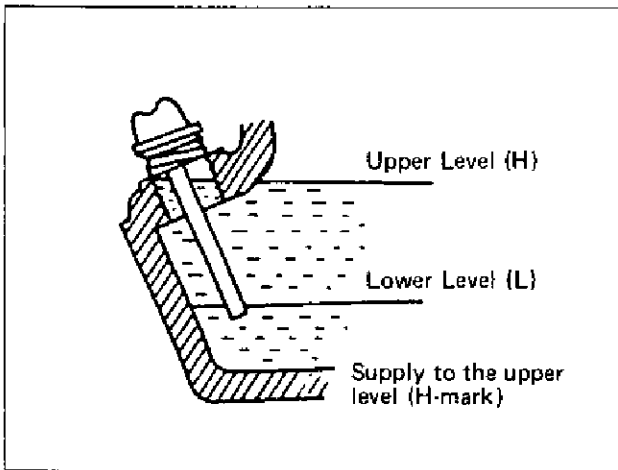

Engine Oil Level

3. Fill fuel tank (See Fuels and Lubricants section).

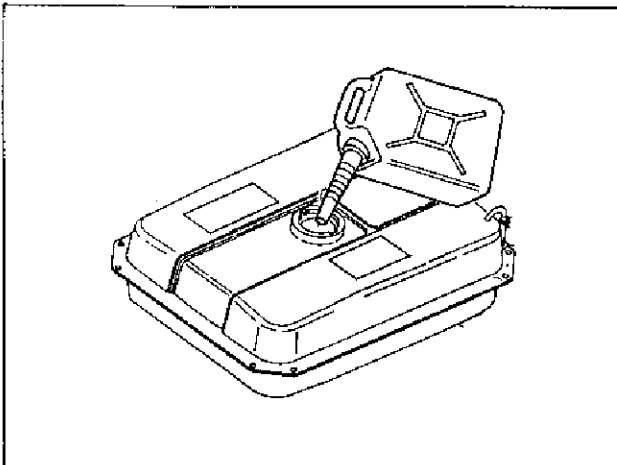

4. Open fuel valve by pushing lever (A) down.

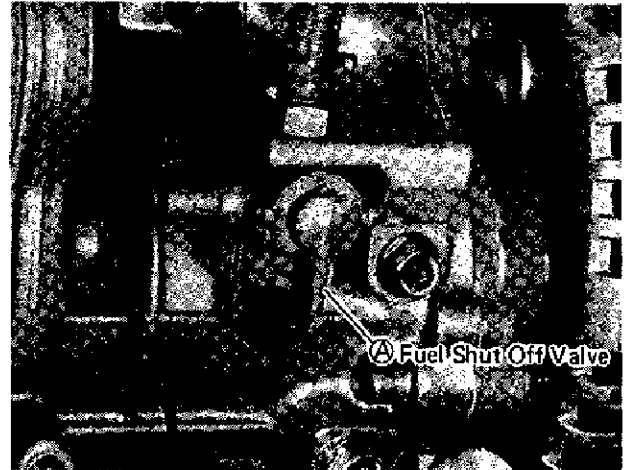

5. Models EG-2300, 3500, 4300 turn the AC circuit breakers off.

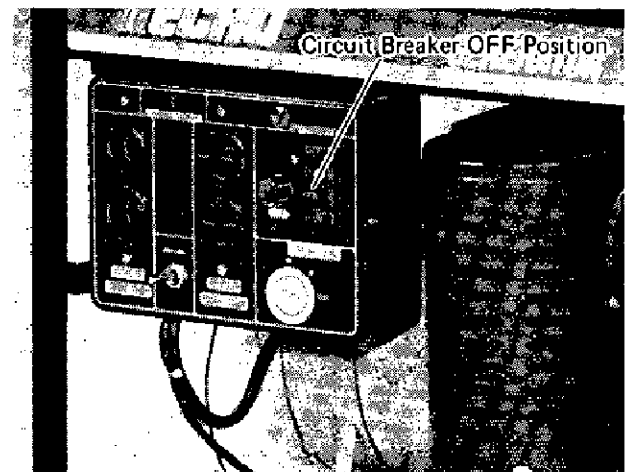

Breaking in a New Engine

Breaking in a new engine is very important. During the first 20 hours (considered the breaking in period), the engine will require special operating attention.

CAUTION:

Subjecting the generator to heavy or maximum usage during the breaking in period could result in serious engine damage.

ENGINE BREAK IN REQUIREMENTS

- A. Allow engine to warm up at idle no-load for 5 minutes after starting engine.
- B. Avoid peak power loads during the break in period. Run only small power tools or appliances requiring low wattage.

Prestart Checks and Operating The Engine

COLD START

6. A) Place combination throttle/choke lever to (choke cold start) position for Models EG-1500, EG-2300, EG-3500.

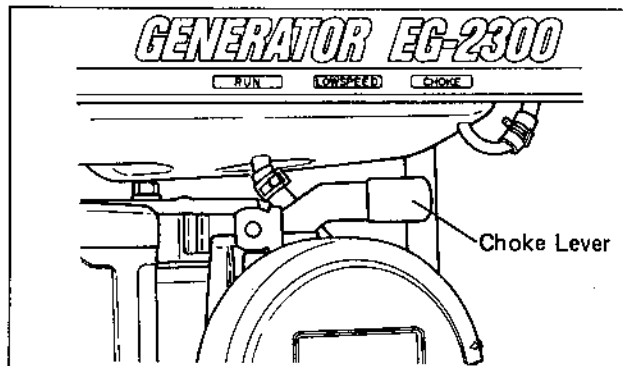

- B) For Model EG-4300 place the choke lever in the closed position - push the choke lever to the left. Place the throttle lever in the "RUN" position.

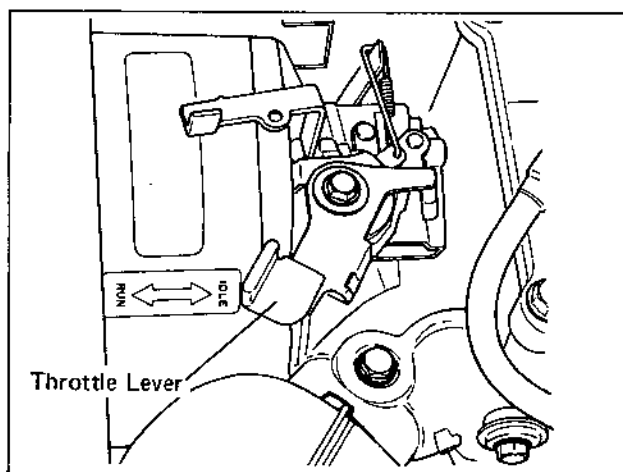

NOTE:

Choke is used only to start a cold engine. In cold weather it may be necessary to leave the throttle lever (Model EG-4300 choke lever) in the choke/cold start position for a brief period after the engine starts.

- C) A hot engine requires no choke. Start the engine with choke/throttle lever set in the idle position for all models excluding EG-4300.
- D) EG-4300 - For moderate air temperatures, turn the choke lever clockwise to half closed position and throttle lever to "RUN" position. Hot engine requires not choke. Set the throttle lever to the "RUN" position.
7. Turn ignition switch to "ON" position.

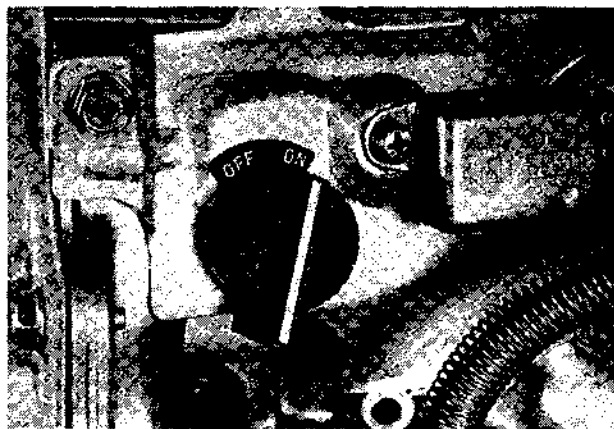

STARTING THE ENGINE

IMPORTANT:

Recoil starter may be damaged if starter handle is pulled abruptly, is allowed to snap back, or is pulled while engine is running.

8. Firmly grasp generator frame with your left hand.
9. With your right hand, slowly pull the starter handle until you feel the starter engage, approximately 3 to 4 inches.
10. With a smooth, rapid motion pull the starter handle. It may require several pulls before engine starts.

Allow starter rope to recoil back in slowly when engine starts.

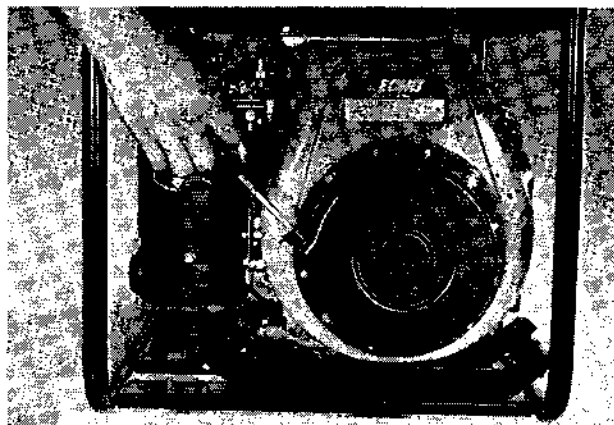

11. After the engine starts, move choke/throttle lever to the idle position and let the engine warm up for 2 ~ 3 minutes.
 - A) Model EG-4300 - After the engine starts, move the choke lever to the "OFF" position (counter clockwise) to the right. Place the throttle lever in the idle position and let the engine warm up for 2 ~ 3 minutes.

Prestart Checks and Operating The Engine

- If the engine fails to start, use the cold start procedure and repeat steps.
- (All Units) - After engine warms up, place throttle lever in the "RUN" full throttle position.

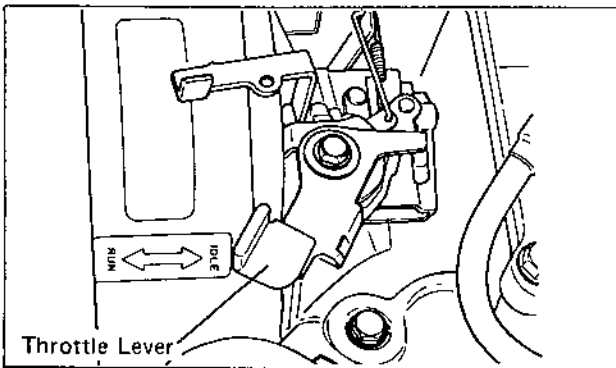
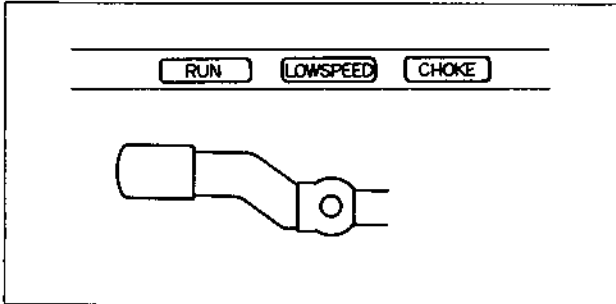

- Turn the circuit breakers (on models EG-2300, EG-3500, EG-4300) and plug in tools or appliance.

⚠ WARNING:

Make sure the engine is operating at full throttle in the "RUN" position before connecting tools or appliances. **DO NOT** set throttle lever at intermediate position or idle while appliances are connected as damage to generator or appliance could result.

LOW OIL LEVEL SHUTDOWN SYSTEM

If engine oil level is low or generator is placed on an incline exceeding 25°, "Low Oil Alert Lamp" (red) will come on. Engine will continue to run approximately two seconds. Low oil level shutdown system is designed to automatically stop the engine to prevent damage. (See Checking Engine Oil Level in Fuels and Lubricants section)

This is only an emergency device and is not intended to indicate when oil is needed.

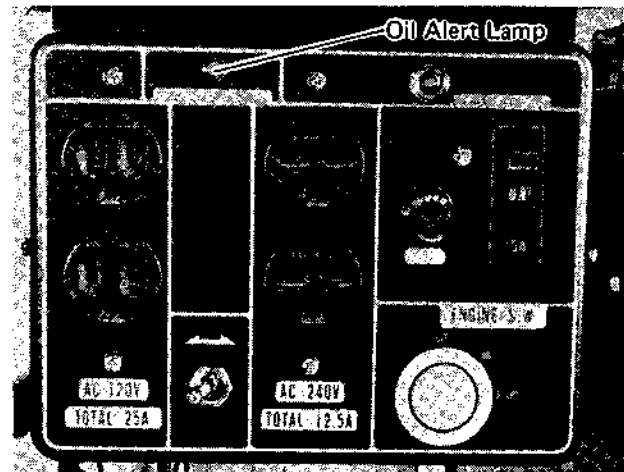

STOPPING THE ENGINE

⚠ IMPORTANT:

Damage to the generator or appliance may result if generator is stopped under load. (with tools or appliances connected)

- Disconnect all power cords from generator receptacles, including the (DC) 12 volt charger if it is being used (Models EG-1500, EG-2300.)
- Turn off AC circuit breakers (Models 2300, 3500, 4300)
- Put throttle (B) in "IDLE" position. Cool engine by idling it for 2 - 3 minutes to cool.
- Turn engine switch (C) to "OFF" position.
- Close fuel valve by moving lever to horizontal position (A).

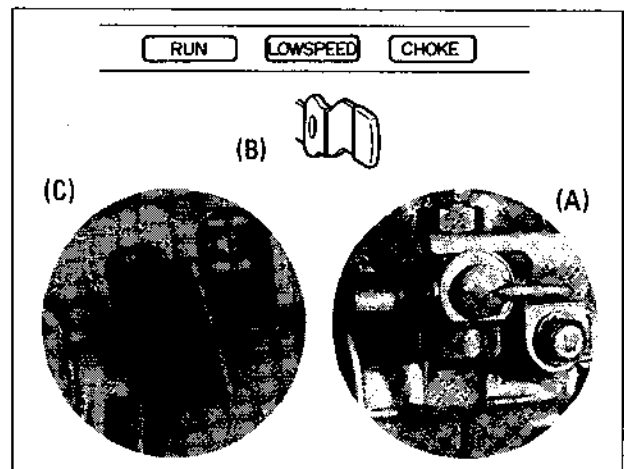

⚠ WARNING:

Allow generator and engine to cool before touching the unit or transporting the generator. Never touch a hot engine or muffler.

⚠ WARNING:

Do not attempt to make any electrical repairs or alter the unit in any way. All repairs and maintenance, other than what is explained in the General Maintenance section of your owner's manual, should be made by an authorized ECHO servicing dealer.

Service/before each use

CHECKING ENGINE OIL LEVEL

⚠ IMPORTANT:

Never check or add oil while engine is running.

1. Stop engine and place generator on a level surface.
2. Wipe dirt and dust from around dipstick area.
3. Remove dipstick(A) and wipe clean.
4. Install dipstick.
5. Remove dipstick to check oil level.
6. Oil must be in between L and H marks.

⚠ IMPORTANT:

If oil level is at or below bottom of L mark on dipstick, do not run the engine.

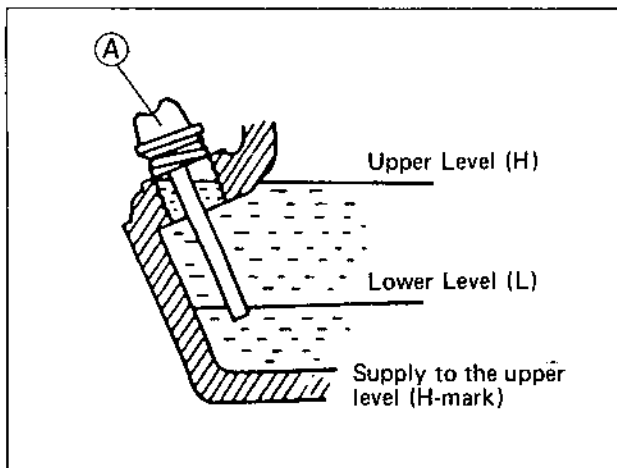

Engine Oil Level

7. If oil level is low, add oil to bring oil level no higher than H mark area of dipstick. (See Engine Oil in Fuels and Lubricants section for correct oil)

⚠ IMPORTANT:

Check O-ring placement and condition on dipstick before installing.

8. Install dipstick and tighten finger tight.

⚠ CAUTION:

The generator should be placed on a flat surface when refilling the crankcase. If the generator is tilted, over filling will result, causing the oil temperature to increase to the danger level during operation. If too little oil is added, serious engine damage could result.

CLEANING AIR FILTER ELEMENT

⚠ IMPORTANT:

Do not run engine with element removed.

AIR FILTER SERVICE

The air filter function is to keep dust and dirt out of the engine. Operating the generator with a dirty or defective filter can lead to costly engine damage. Always replace the filter if torn or damaged. A dirty air filter will restrict the flow of air to the carburetor. To prevent carburetor problems, service the air filter regularly (25 hrs.). Service the filter more frequently when operating the generator in extremely dusty areas.

⚠ CAUTION:

Never run the generator without the air filter. Rapid engine wear or damage will result.

⚠ WARNING:

Never use gasoline or low flash point solvent for cleaning the air cleaner element, a fire or explosion could result.

TO CLEAN AIR FILTER:

1. Brush or wipe away any dust, dirt or debris from around the air filter cover.
2. Model EG-1500, EG-2300
 - A) Pull or pry out the right hand side of the air cleaner cover marked "OPEN" and lift cover off.

General Maintenance

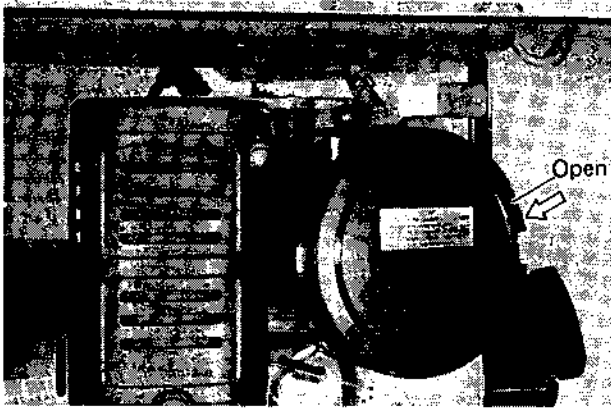

3. Model EG-3500 - Unsnap the air filter cover retaining clip forward towards you and lift cover off.

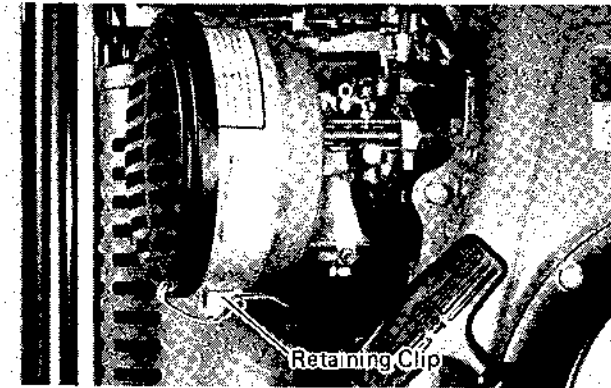

4. Remove foam element from air cleaner box.
5. Wash element in liquid detergent and warm water. Wrap element in cloth and squeeze dry.
6. Soak element in clean SAE30 weight engine oil. Squeeze to remove excess oil, then wrap in clean cloth and squeeze as dry as possible. (Be careful not to tear element.)
7. Remove air filter back plate and clean with cleaning solvent.



Air Filter Cover

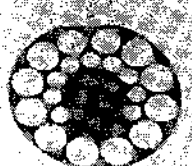

Back Plate



Foam Filter

- A. Dampen a clean cloth in solvent and wipe interior of a airbox.

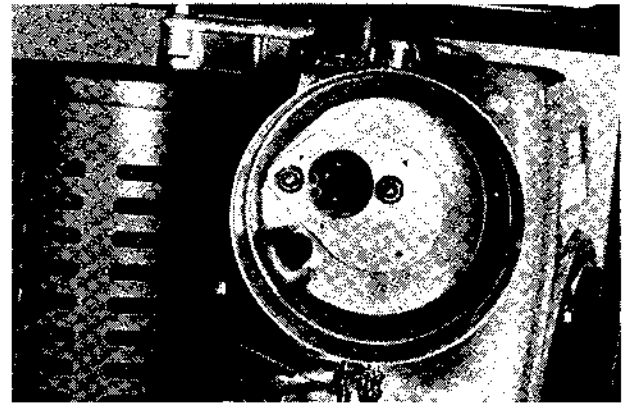

- B. Reinstall air filter back plate (Note see proper orientation).
- C. Reinstall air filter.
- D. Reinstall air filter cover. Make sure the cover fits flush and is fastened securely.

TO CLEAN AIR FILTER MODEL EG-4300

1. Brush or wipe away any dust, dirt or debris from around the air filter cover.
2. Unsnap two air filter cover retaining clips forward towards you and pull the cover off.

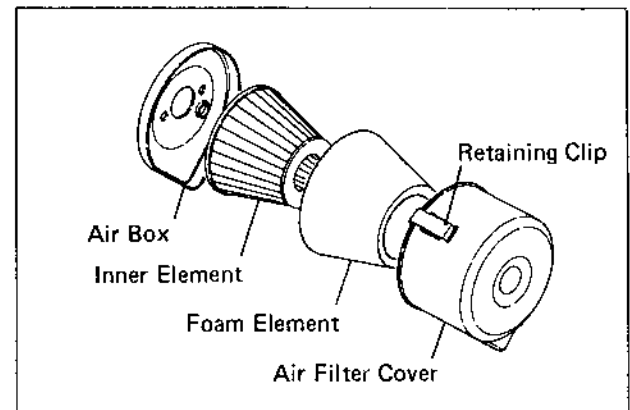

NOTE:

The Model EG-4300 is equipped with a two piece air filter element.

3. Remove foam outer element from around the air filter.
4. Wash the foam element in liquid detergent and warm water. Wrap the foam element in cloth and squeeze dry.

5. Soak the foam element in clean SAE-30 weight engine oil. Squeeze to remove excess oil, then wrap in clean cloth and squeeze as dry as possible (be careful not to tear element).
6. Clean the inner air cleaner element by gently tapping it on a flat surface. If possible, use compressed air and clean the air filter by blowing air from inside of the air cleaner to the outside. If the inner element is very dirty, replace it.
7. Dampen a clean cloth in solvent and clean the interior of the air box and air cleaner cover.
8. Install outer foam element around inner element.
9. Reinstall air filter.
10. Reinstall air filter cover/make sure cover fits flush and is fastened securely.

NOTE:

Air filter should be cleaned periodically. Replace filter if torn or damaged.

SPARK PLUG MAINTENANCE

The spark plug (L-90.Champion or equivalent) should be cleaned periodically and changed as required.

To remove spark plug:

- A. Turn engine On/Off switch to STOP position.

CAUTION:

Before checking spark plug:

- Stop engine
- Wait for engine to cool

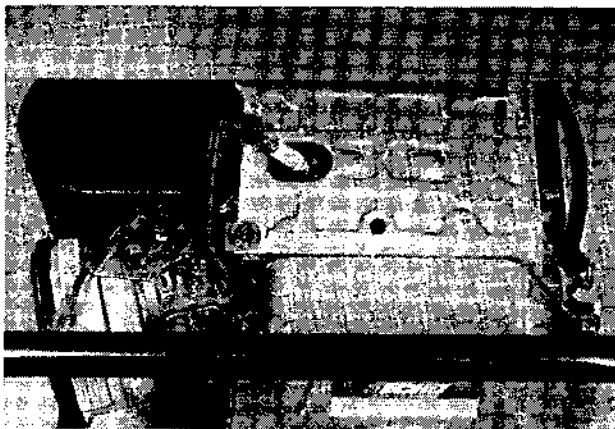

- B. Disconnect rubber spark plug boot connect by twisting and pulling at the same time clean any dirt from around the spark plug base.

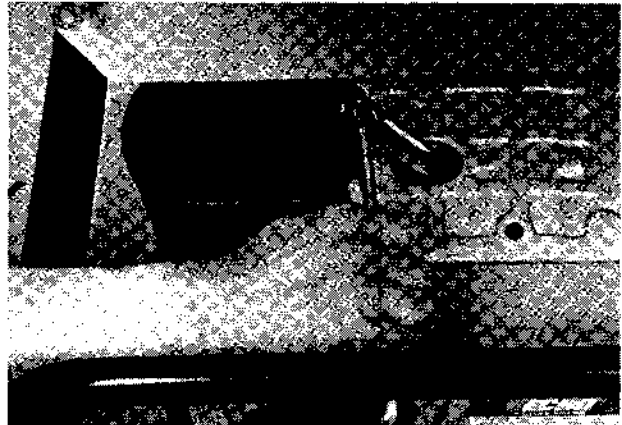

- C. Remove spark plug with a spark plug socket wrench. Do not use any other type tool.

IMPORTANT:

Do not clean spark plugs in a machine using abrasives.

Clean spark plug by carefully scraping or with a wire brush.

WEAR FULL EYE PROTECTION DURING THIS OPERATIONS

- D. Visually inspect the spark plug. Discard it if the porcelain insulator is cracked, shipped. Discard if electrodes are pitted or damaged.
- E. Check plug gap with a wire feeler gauge.

Gap must be 0.6 ~ 0.7 mm (0.024 ~ 0.028 in.).

To change gap bend only side electrode, using spark plug tool.

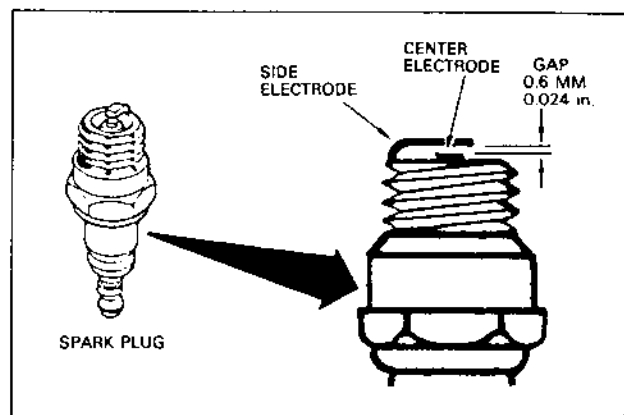

General Maintenance

- F. Attach the plug washer and thread the plug in by hand to prevent cross threading.
- G. After a new spark plug has been seated by hand it should be tightened 1/2 turn with a wrench to compress the seat washer. If a used plug is being re-installed, it should only be tightened 1/8 ~ 1/4 turn after being seated.

CAUTION:

Never use a spark plug with improper seat range. Recommended spark plug L-90 Champion or equivalent.

FUEL TANK STRAINER

The fuel tank filter should be cleaned as required.

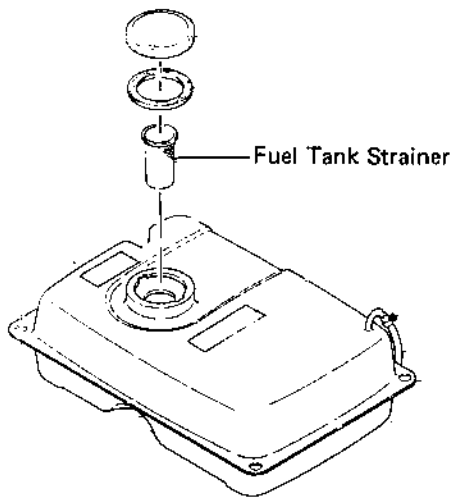

- A. To clean fuel strainer, remove fuel tank cap and lift out filter.
 - Wash in clean solvent.
 - Reinstall.

FUEL VALVE/FUEL BOWL

The fuel bowl should be removed and cleaned after 100 hours of operation or more frequently if sediment or water is visible.

CAUTION:

Before you work on fuel system

- Stop engine
 - Wait until engine is cool
1. Close fuel valve by turning lever (A) to horizontal position.
 2. Loosen and remove sediment bowl (B).

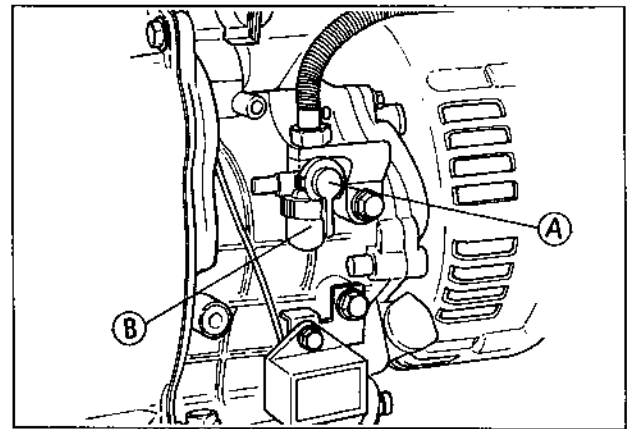

3. Remove filter insert from sediment bowl and clean all parts.

IMPORTANT:

Check seal placement and condition on filter insert before installing.

4. Reassemble filter insert and seal into sediment bowl.
5. Install sediment bowl assembly on generator and tighten.
6. Open fuel valve.
7. Start engine and check for leaks.

SPARK ARRESTER SCREEN/EXHAUST OUTLET

An improperly maintained clogged spark arrester screen can cause engine power loss and faulty functioning of exhaust system.

CAUTION:

Never operate unit without a spark arrester screen installed. (See Safety Instructions)

To clean or replace spark arrester screen:

CAUTION:

Do not touch or attempt this operation if the muffler or engine is hot. Allow unit to cool.

- A. Remove retaining screw above exhaust outlet and detach spark arrester screen.
- B. Use a wooden scraper or small wire brush to scrape away any dirt or carbon deposits from exhaust outlet opening and spark arrester screen.
- C. Reinstall spark arrester screen.



NOTE:

Spark arrester screen should be inspected daily to make sure screen is not clogged by carbon deposits. Screen should be cleaned and replaced as required.

To maintain efficiency the spark arrester screen should be changed every 100 hours.

Storage

STORING FOR SHORT TIME BETWEEN JOBS

(90 days or less)

CAUTION:

Store generator in a dry place, out of reach of children. Do not store in an enclosure where fuel fumes may accumulate or reach an open flame or spark.

1. Clean, exterior of generator to remove all accumulations of grease, oil, dirt, or debris.
2. Perform any periodic lubrication or services are required.
3. Tighten all cap screws and nuts.
4. Touch-up paint as required.
5. Remove spark plug cable to help prevent accidental starting.
6. Close fuel valve.
7. Place a suitable cover generator.

STORING FOR LONG TIME BETWEEN JOBS

(Longer than 90 days)

NOTE:

Follow all procedures above plus the following steps:

Do not store generator for a prolonged period of time (3 months or longer) without performing protective storage maintenance which includes the following procedures:

- A. Changing engine oil.
 - B. Lubricating combustion chamber.
 - C. Draining and cleaning fuel tank and filter.
 - D. Draining carburetor and cleaning fuel bowl and strainer.
1. Change engine oil.
(See Changing Engine Oil in Service/ 50 hours section.)
 2. Remove spark plug and pour 1/3 oz (10 ml) of fresh engine oil into cylinder.
 3. Place clean rag over spark plug hole.
 4. Pull recoil starter handle twice to distribute oil.
 5. Install spark plug leaving cable detached.
 6. Close engine valves by pulling recoil starter handle until compression is felt, then pull handle 3 ~ 4 cm (1 ~ 2 in.) further.

7. Remove fuel bowl and drain fuel from tank and lines into an approved fuel container. Reinstall fuel bowl and tighten.
8. Drain fuel from carburetor float bowl by loosening carburetor drain plug.

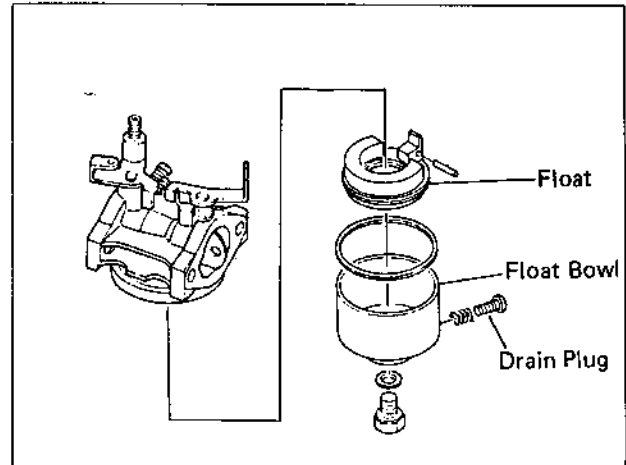

REMOVING GENERATOR FROM STORAGE

Turn ignition On/Off switch to STOP position.

1. Check engine oil level.
2. Remove spark plug. Cover spark plug hole with clean rag.
3. Pull recoil starter handle several full strokes to remove oil from cylinder.
4. Check spark plug gap; install plug. Connect spark plug cable.
5. Check that guards and shields are fastened in place.
6. Fill fuel tank with correct gasoline
(See Fuels and Lubricants section).
7. Turn the fuel valve "ON".
8. Turn ignition switch "ON".
9. Start and run the engine for 5 minutes before connecting an electrical load.

Preventive Maintenance Check Chart

PREVENTIVE MAINTENANCE CHECK CHART

ITEM	MAINTENANCE	DAILY	EVERY 50 Hrs.	EVERY 100 Hrs.	EVERY 300 Hrs.	EVERY 1000 Hrs.	As Req.
Screws/Nuts/Bolts	Inspect & Tighten	•					
Fuel Tank	Check & Refill Clean	•					•
Spark Plug	Clean & Adjust Replace			•			•
Engine Oil	Check Change	•	•*				
Air Filter	Inspect Replace	•					•
Spark Arrester Screen	Inspect Replace	•					•
Exhaust Port	Clean		•				
Fuel Tank Filter	Clean			•			
Fuel Bowl/Strainer	Clean			•			
Fuel/Oil Hoses	Inspect Replace*	•					•
Starter Rope	Inspect Replace*	•					•
Carburetor	Clean*				•		
Piston Ring	Replace*						•
Shock Mounts	Inspect Replace*	•					•
Starter Cover	Clean	•					
Controls	Inspect	•					
Ignition Switch	Inspect	•					
Circuit Breaker	Inspect Replace*	•					•
Fuse	Inspect Replace	•					•
Receptacles	Inspect Replace*	•					•
Intake Valves	Reface Replace*						•
Exhaust Valves	Reface Replace*						•
Generator Brushes	Replace*					•	

** First oil change at 20 hours

* Recommended for maintenance by an authorized ECHO servicing dealer.

Troubleshooting

TROUBLESHOOTING

SYMPTOM	POSSIBLE CAUSE	CORRECTIVE ACTION
Engine does not start	<ol style="list-style-type: none"> 1. Unit loaded during start-up 2. Low on fuel or oil 3. Faulty spark plug 4. Loose wire 5. Ignition switch off 6. Fuel valve off 	<ol style="list-style-type: none"> 1. Remove load 2. Add fuel or oil 3. Replace 4. Inspect & repair 5. Turn to ON position 6. Turn to ON position
No electrical output	<ol style="list-style-type: none"> 1. Faulty Circuit Breaker 2. Faulty Receptacle 3. Faulty Fuse 4. Circuit Breaker 5. Faulty Power Cord 	<ol style="list-style-type: none"> 1. a) Reset b) Replace 2. Replace 3. Replace 4. Turn to ON position 5. Inspect & replace
Repeated circuit breaker tripping or fuse failure	<ol style="list-style-type: none"> 1. Overload 2. Faulty equipment or cords. 	<ol style="list-style-type: none"> 1. Reduce load 2. Check for bare wires or frayed insulation on equipment

TROUBLESHOOTING

When the engine will not start:

1. Is there enough fuel?
2. Is the fuel valve on?
3. Is gasoline reaching the carburetor?
To check, loosen the drain screw at the carburetor float bowl with the fuel valve on.
4. Is the engine ignition switch "ON"?
5. Is there enough oil in the engine?
If not, the oil alert lamp will go on when the starter grip is being pulled.
6. Is there a spark at the spark plug?
 - a) Remove the spark plug cap. Clean any dirt from around the spark plug base, then remove the spark plug.
 - b) Install the spark plug in the plug cap.
 - c) Turn the engine switch on.
 - d) Ground the side electrode of the spark plug to any engine ground, pull the recoil starter to see if sparks jump across the gap.
 - e) If there are no sparks, replace the plug. If OK, try to start the engine according to the instructions.
7. If the engine still does not start, take the generator to the nearest **ECHO** dealer.

CAUTION:

If any fuel is spilled, make sure the area is dry before testing the spark plug or starting the engine. Fuel vapor or spilled fuel may ignite.

