



GENERATOR



EG-10000 OPERATOR'S MANUAL

MODEL EG-10000
SERIAL NUMBER EG-190628- A0000001 & UP

Introduction	
Using the Operator's Manual	4
Product Identification	
Generator	5
Engine	5
Safety	
Safety Rules	6
Hazard Symbols and Meanings	6
Ground Fault Circuit Interrupter Protection	9
Important Safety Instructions.....	11
Generator Components	
EG-10000 Component Chart.....	13
Preparing the Generator	
Grounding the Generator	14
Pre-Operation Checklist	
Engine Oil	15
Fuel	15
General Recommendations	16
Fuel Type	16
Gasoline/Alcohol Blends	16
Gasoline/Ether Blends	16
Check Component Parts	16
Check Generator Surroundings	17
Starting the Generator	
Recoil Start	17
Electric Start	19

Operation	
Using Electric Power	20
AC Application	20
DC Application	21
Connection of Cable	21
Safety Precautions While Charging	21
Wattage Information	22
Spark Arrester	23
How To Remove The Spark Arrester	23
Clean The Spark Arrester Screen	23
Stopping the Generator	
Stopping the Generator	24
Oil Sensor	24
Troubleshooting	
Troubleshooting Chart	25
Maintenance	
Maintenance Schedule	26
Daily Inspection	26
Periodic Maintenance	26
Changing Engine Oil	27
Servicing The Air Cleaner	27
Cleaning and Gapping Spark Plug	27
Cleaning Fuel Strainer	27
Periodic Operation and Inspection	27
Transporting	
Transporting	28
Storage	
Storage	29
Generator Specifications	30
Warranty	
High Altitude Replacement Kit	31
Warranty Statement.....	32
CARB and EPA Warranty	34



Attention: Read through the complete manual prior to the initial use of your generator.

Using the Operator's manual

The operator's manual is an important part of your generator. It should be read thoroughly before initial use, and referred to often to make sure adequate safety and service concerns are being addressed.

Reading the operator's manual thoroughly will help avoid any personal injury or damage to your machine. By knowing how best to operate this machine you will be better positioned to show others who may also operate the unit.

This manual contains information for the complete range of generators, and was written to take you from the safety requirements to the operating functions of your machine. You can refer back to the manual at any time to help troubleshoot any specific operating functions, so store it with the machine at all times.



Record Identification Numbers

GENERATOR

If you need to contact an Authorized Dealer or Customer Service line for information on servicing, always provide the product model and identification numbers.

You will need to locate the model and serial number for the machine and record the information in the places provided below.

Date of Purchase:
Dealer Name:
Dealer Phone:

Product Identification Numbers
Model Number:
Serial Number:

To ensure trouble free warranty coverage it is important that you register your ECHO on-line at:

<http://www.echo-usa.com/Warranty/Register-Your-ECHO>

Save these Instructions

SAFETY RULES



This is the safety alert symbol. It is used to alert you to potential personal injury hazards. Obey all safety messages that follow this symbol to avoid possible injury or death.

The safety alert symbol () is used with a signal word (DANGER, CAUTION, WARNING), a pictorial, and/or a safety message to alert you to hazards.

DANGER indicates a hazard which, if not avoided, will result in death or serious injury.

WARNING indicates a hazard which, if not avoided, could result in death or serious injury.

CAUTION indicates a hazard which, if not avoided, might result in minor or moderate injury.

NOTICE indicates a situation that could result in equipment damage. Follow safety messages to avoid or reduce the risk of injury or death.

Hazard Symbols and Meanings



EXPLOSION



FIRE



ELECTRIC SHOCK



TOXIC FUMES



KICKBACK



READ MANUAL

⚠ WARNING

Generator exhaust contains carbon monoxide, a poisonous gas that can kill you.

You CANNOT smell or see this gas.

- Use the generator outdoors, away from open windows, vents, or doors that could allow the carbon monoxide gas to come indoors. Keep the generator at least 1 meter (3 feet) away from any structure or building during use.
- NEVER use a generator indoors, including in homes, garages, basements, crawl spaces, and other enclosed or partially enclosed areas, even with ventilation. Opening doors and windows or using fans will not prevent carbon monoxide build-up in the home.
- NEVER use a generator in enclosed or partially-enclosed spaces.
- Generators can produce high levels of carbon monoxide very quickly. When you use a portable generator, remember that you cannot smell or see carbon monoxide. Even if you can't smell exhaust fumes, you may still be exposed to carbon monoxide.
- NEVER operate the generator in an explosive atmosphere, near combustible materials or where ventilation is not sufficient to carry away exhaust fumes. Exhaust fumes can cause serious injury or death.
- If you start to feel sick, dizzy, or weak while using a generator, get to fresh air RIGHT AWAY. DO NOT DELAY. The carbon monoxide from generators can rapidly lead to full incapacitation and death.
- If you experience serious symptoms, get medical attention immediately. Inform medical staff that carbon monoxide poisoning is suspected. If you experienced symptoms while indoors, have someone call the fire department to determine when it is safe to re-enter the building.



Cancer and Reproductive Harm
 Cáncer y Daño Reproductivo
 Cancer et dommages à la reproduction
www.P65Warnings.ca.gov

⚠ WARNING

Fuel and vapors are extremely flammable and explosive.



Fire or explosion can cause severe burns or death.

WHEN ADDING OR DRAINING FUEL

- Observe all safety regulations for the safe handling of fuel. Handle fuel in safety containers. If the container does not have a spout, use a funnel.
- Do not overfill the fuel tank, leave room for the fuel to expand.
- Do not refill fuel tank while the engine is running. Before refueling the generator, turn it off and let it cool down. Gasoline spilled on hot engine parts could ignite.
- Fill the tank only on an area of bare ground. While fueling the tank, keep heat, sparks and open flame away. Carefully clean up any spilled fuel before starting engine.
- Always fill fuel tank in an area with plenty of ventilation to avoid inhaling dangerous fumes.
- NEVER store fuel for your generator in the home. Gasoline, propane, kerosene, and other flammable liquids should be stored outside of living areas in properly-labeled, non-glass safety containers. Do not store them near a fuel-burning appliance, such as a natural gas water heater in a garage. If the fuel is spilled or the container is not sealed properly, invisible vapors from the fuel can travel along the ground and can be ignited by the appliance's pilot light or by arcing from electric switches in the appliance.

Ground Fault Circuit Interrupter Protection

These generators are equipped with a GFCI (Ground Fault Circuit Interrupters) 120V duplex receptacles for protection against the hazards of electrical shock from defective attachments such as, tools, cords, and cables.

 **WARNING**

The GFCI may not function unless the generator is properly grounded. Follow the correct procedure specified in the section labeled **GROUNDING INSTRUCTIONS**.

A GFCI is a device that interrupts electricity from either the utility or generator by means of a special type of circuit breaker that determines if a current flow to the ground occurs.

A GFCI can be used only with generators that have the neutral wire internally bonded to the frame, and the frame properly grounded to the earth. A GFCI will not work on generators that do not have the neutral wire bonded to the frame, or on generators which have not been properly grounded.

This product has been designed with internal grounding or floating bonded neutral. If it should malfunction or breakdown, grounding provides a path of least resistance for electric current to reduce the risk of electric shock.

DANGER

Improper grounding can result in a risk of electrocution. Check with a qualified electrician for your local requirements if you are in doubt as to whether the unit is properly grounded.

This generator is equipped with a grounding terminal for added protection. Using the ground path from the generator to an external ground source as instructed in the section labeled "Grounding Instructions" in the PREPARING THE GENERATOR section of this manual can be necessary. Please consult a qualified electrician for local regulations.



The generator is a potential source of electrical shock if not kept dry. Keep the generator dry and do not use in rain or wet conditions. To protect from moisture, operate it on a dry surface under an open, canopy-like structure. Dry your hands if wet before touching the generator.

Plug appliances directly into the generator. Or, use a heavy duty, outdoor-rated extension cord that is rated (in watts or amps) at least equal to the sum of the connected appliance loads. Check that the entire cord is free of cuts or tears and that the plug has all three prongs, especially a grounding pin.

NEVER try to power the house wiring by plugging the generator into a wall outlet, a practice known as "back feeding". This is an extremely dangerous practice that presents an electrocution risk to utility workers and neighbors served by the same utility transformer. It also bypasses some of the built-in household circuit protection devices.

If you must connect the generator to the house wiring to power appliances, have a qualified electrician install the appropriate equipment in accordance with local electrical codes.

IMPORTANT SAFETY INSTRUCTIONS

 WARNING	
	<p>To reduce the risk of injury, read this operator's manual completely before using.</p> <p>When using this product, the following basic precautions should always be followed.</p>

- Do not enclose the generator or cover it. The generator may become overheated if it is enclosed.
- If generator has been covered to protect it from the weather during non use, be sure to remove it and keep it well away from the area during generator use.
- Operate the generator on a level surface. It is not necessary to prepare a special foundation for the generator. However, the generator will vibrate on an irregular surface, so choose a level place.
- If the generator is tilted or moved during operation, fuel may spill and/or the generator may tip over, causing a hazardous situation. Proper lubrication cannot be expected if the generator is operated on a steep incline or slope. In such a case, piston seizure may occur even if the oil is above the upper level.
- Pay attention to the wiring or extension cords from the generator to the connected device. If the wire is under the generator or in contact with vibrating part, it may break and possibly cause a fire, generator burnout, or electric shock hazard. Replace damaged or worn cords immediately.
- Do not operate in rain, in wet or damp conditions, or with wet hands. The operator may suffer severe electric shock if the generator is wet due to rain or snow. If wet, wipe and dry it well before starting. Do not pour water directly over the generator, nor wash it with water.
- Be extremely careful that all necessary electrical grounding procedures are followed during each and every use. Failure to do so can be fatal.
- DO NOT smoke while charging a battery. The battery emits flammable hydrogen gas, which can explode if exposed to electric arcing or open flame. Keep the area well ventilated and keep open flames / sparks away when charging a battery.
- The engine becomes extremely hot during and for some time after operation. Keep combustible materials well away from generator

area. Be very careful not to touch any parts of the hot engine especially the muffler area or serious burns may result.

- Keep children and all bystanders at a safe distance from work area.
- It is absolutely essential that you know the safe and proper use of the power tool or appliance that you intend to use. All operators must read, understand and follow the tool / appliance owners manual. Tool and appliance applications and limitations must be understood. Follow all directions given on labels and warnings. Keep all instruction manuals and literature in a safe place for future reference.
- Use only "LISTED" extension cords. When a tool or appliance is used outdoors, use only extension cords marked "For Outdoor Use" Extension cords, when not in use should be stored in a dry and well ventilated area.
- Always switch off generator's AC circuit breaker and disconnect tools or appliances when not in use, before servicing, adjusting, or installing accessories and attachments.
- Make sure the engine is stopped before starting any maintenance, servicing or repair.

NOTE: Make sure maintenance and repair of the generator are performed by properly trained personnel only.

SAVE THESE INSTRUCTIONS



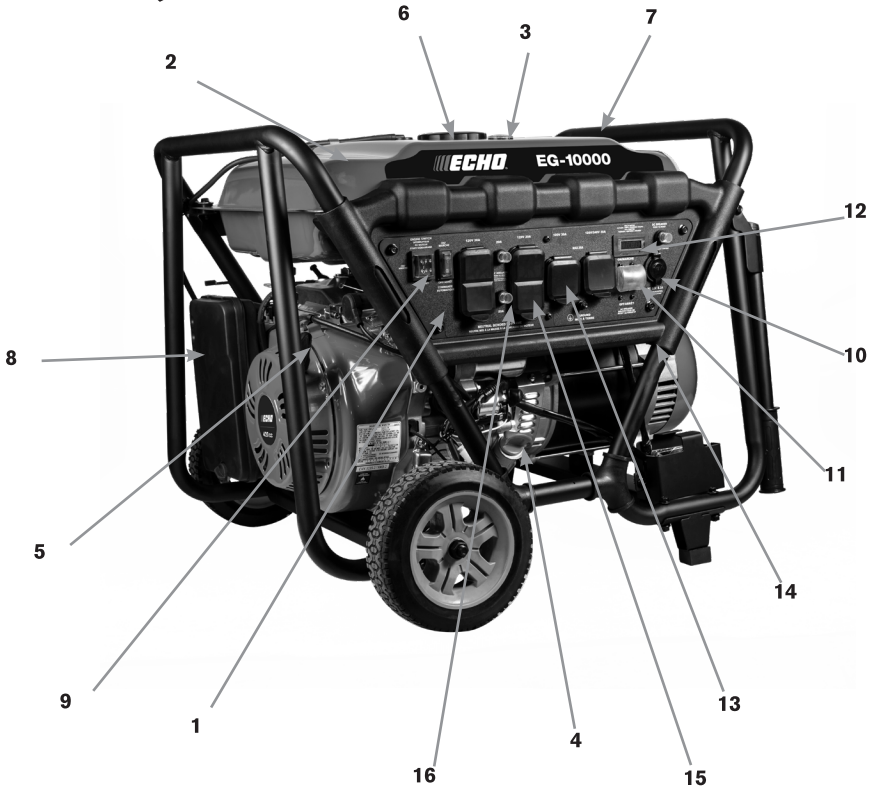

Read this operator's manual and safety rules before operating your generator.



- | | |
|-------------------|--|
| 1. Control Panel | 10. DC Connection |
| 2. Fuel Tank | 11. DC Breaker |
| 3. Fuel Gauge | 12. Hourmeter/Service maintenance code indicator |
| 4. Oil dipstick | 13. 120V 3 Prong Twistlock |
| 5. Recoil Starter | 14. Ground |
| 6. Tank Cap | 15. 120V GFCI |
| 7. Frame | 16. AC Breaker |
| 8. Air Cleaner | |
| 9. ON/OFF Switch | |

GROUNDING INSTRUCTIONS

 DANGER	
	Improper connection of the equipment grounding conductor can result in a risk of electrocution.
Check with a qualified electrician if you are in doubt as to whether the unit is properly grounded for your local regulations.	

The ground terminal on the frame can be used to connect the generator to a suitable ground source. The ground path should be made with #8 size wire. Connect the grounding wire securely to the ground terminal. Connect the other end of the wire securely to a suitable ground source.

A metal underground water pipe in direct contact with the earth for at least 10ft (3.0m) can be used as a grounding source. If a pipe is unavailable, an 8ft (2.4m) length of pipe or rod may be used as the ground source. The pipe should be 3/4"(1.9cm) diameter or larger and the outer surface must be noncorrosive. If a steel or iron rod is used it should be at least 5/8" (1.6cm) diameter and if a nonferrous rod is used it should be at least 1/2" (1.2cm) diameter and be listed as material for grounding. Drive the rod or pipe to a depth of 8ft (2.4m). If a rock bottom is encountered less than 4ft (1.2m) down, bury the rod or pipe in a trench. All electrical tools and appliances operated from this generator, must be properly grounded by use of a third wire or be "Double Insulated".

It is recommended to:

1. Use electrical devices with 3 prong power cords.
2. Use an extension cord with a 3 hole receptacle and a 3 prong plug at the opposite ends to ensure continuity of the ground protection from the generator to appliance.

We strongly recommend that all applicable regulations relating to grounding specifications be checked and followed.

Pre-Operation

ENGINE OIL

Before checking or refilling oil, be sure generator is located on stable and level surface with engine stopped. **This generator uses SAE 10W30 oil.**

1. Remove oil dipstick and check the engine oil level.
2. If oil level is below the lower level line, refill with suitable oil to upper level line. Do not screw in the oil dipstick when checking oil level.
3. Change oil if contaminated.

NOTICE	
	Always check the level of the engine oil prior to starting the generator.
<ul style="list-style-type: none"> • Failure to do so could cause the engine to seize if the oil is low or empty. 	

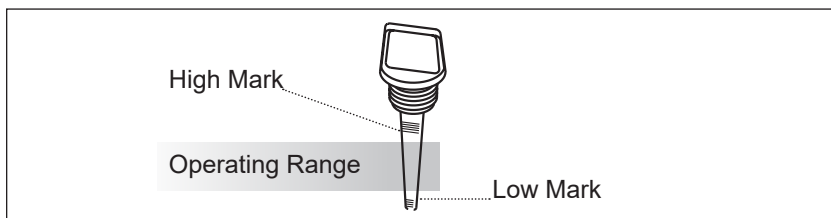

FUELING

WARNING	
	Explosive Fuel! Gasoline is extremely flammable and its vapors can explode if ignited.
<ul style="list-style-type: none"> • DO NOT refuel while smoking or near open flame or other such potential fire hazards. • Store gasoline only in approved containers, in well ventilated, unoccupied buildings and away from sparks or flames. • DO NOT fill the tank while the engine is hot or running, since spilled fuel could ignite if it comes in contact with hot parts or sparks from ignition. • DO NOT start the engine near spilled fuel. • NEVER use gasoline as a cleaning agent. 	

⚠ WARNING

DO NOT overfill the tank, leave room for the fuel to expand.

1. If fuel level is low, refill with unleaded automotive gasoline.
2. Check fuel gauge while filling.
3. When using the generator for the first time or stopping due to the fuel running out, pull the recoil handle several times after filling the tank.

GENERAL RECOMMENDATIONS

- Purchase gasoline in small quantities and store in clean, approved containers.
- To minimize gum deposits in your fuel system and to insure easy starting, do not use gasoline left over from the previous season.
- Do not add oil to the gasoline.
- Consider adding fuel stabilizer before running or starting the generator.

FUEL TYPE

- For best results use only clean, fresh, unleaded gasoline with an octane rating of 87 or higher.

GASOLINE/ALCOHOL BLENDS

Gasohol (up to 10% ethanol, 90% unleaded gasoline by volume) is approved, as a fuel. Other gasoline/alcohol blends are not approved.

GASOLINE/ETHER BLENDS

Methyl Tertiary Butyl Ether (MTBE) and unleaded gasoline blends (up to a maximum of 15% MTBE by volume) are approved as a fuel. Other gasoline/ether blends are not approved.



CHECK COMPONENT PARTS

Check following items before starting engine:

1. Fuel leakage from fuel hose, etc.
2. Bolts and nuts for looseness.
3. Components for damage or breakage.
4. Generator not resting on or against any adjacent wiring.

CHECK GENERATOR SURROUNDINGS

When listening to the radio near the generator, the radio signal may be disturbed. This may cause distortion or reduced volume from the radio.

⚠ WARNING	
 	<p>Keep area clear of flammables or other hazardous materials.</p>
<ul style="list-style-type: none"> • Keep generator at least 3ft (1m) away from buildings or other structures. • Only operate generators in a dry, well ventilated area. • Keep exhaust pipe clear of foreign objects. • Keep generator away from open flame. No Smoking! • Keep generator on a stable and level surface. • Do not block generator air vents with paper or other material. 	

Starting Your Generator

RECOIL START

⚠ CAUTION
<p>When starting the engine with the recoil start, set the toggle switch in the “ON” position before pulling the starter handle.</p>

1. Make sure all appliances are disconnected from the generator.
2. Move engine choke switch to the START (ON) position. (When the engine is warm or temperature is high, start engine with the switch in the OFF position).

⚠ CAUTION
<p>Do not connect appliances with defective power cords and/or plugs.</p>
<p>Be sure appliances are not connected to generator when starting up. Starting the generator with an appliance connected could result in damage to the generator and/or appliances and personal injury.</p>

3. Pull the recoil starter handle slowly until passing the compression point (resistance will be felt), then return the handle to its original position and pull briskly.

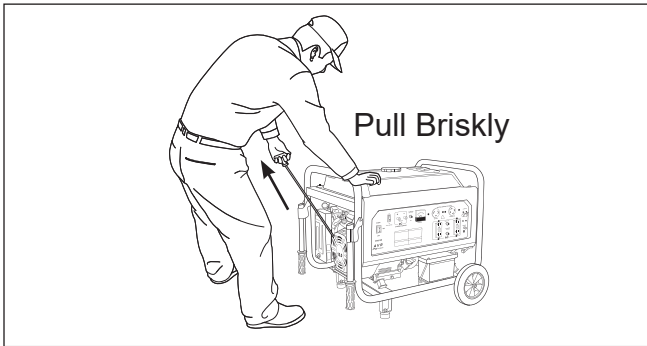

4. After starting, allow the recoil starter handle to return to its original position with the handle still in your hand.

NOTE: *If the engine fails to start after several attempts, repeat the starting procedures mentioned above with the engine choke switch placed in the OFF position.*

5. After 20 to 30 seconds of warm-up is completed, turn the engine choke switch to "OFF" position.
6. Test the GFCI receptacle on the unit. Push the test button. The reset button should pop out and there should be no power at the receptacle.

Apply a test load or lamp to each receptacle to verify. **IF THE RESET BUTTON DOES NOT POP OUT, DO NOT USE THE RECEPTACLE. SEE AUTHORIZED DEALER FOR SERVICE IMMEDIATELY.**

7. If GFCI receptacle tests correctly, firmly push the reset button to restore power. A distinctive click should be heard or felt when this is complete. **IF THE RECEPTACLE DOES NOT RESET PROPERLY, DO NOT USE THE RECEPTACLE. SEE AUTHORIZED DEALER FOR SERVICE IMMEDIATELY**
8. Loads can now be applied to unit.

Electric Start

1. Make sure all appliances are disconnected from the generator.
2. Turn engine choke switch to the START (ON) position. (When the engine is warm or temperature is high, start engine with the choke switch in the “OFF” position).
3. Set the toggle switch to the middle “ON” position. Press and hold the toggle to the start position to engage the starter. Release, set toggle to the “ON” position when engine is running.

 CAUTION
--

Do not connect appliances with defective power cords and/or plugs.
--

- | |
|---|
| <ul style="list-style-type: none">• Be sure appliances are not connected to generator when starting up. Starting the generator with an appliance connected could result in damage to the generator and/or appliances and personal injury.• DO NOT turn the starting motor over 5 seconds continuously . If the engine fails to start, return the toggle switch to the “ON” position and wait about 10 seconds and then start again.• DO NOT press the toggle switch to the “START” position when the engine is running to prevent damage of starting motor. |
|---|

1. After 20 to 30 seconds of warm-up is completed, turn the engine choke switch to the “OFF” position.
2. Test the GFCI receptacle on the unit. Push the test button. The reset button should pop out and there should be no power at the receptacle.

Apply a test load or lamp to each receptacle to verify. IF THE RESET BUTTON DOES NOT POP OUT, DO NOT USE THE RECEPTACLE. SEE AUTHORIZED DEALER FOR SERVICE IMMEDIATELY.

3. If GFCI receptacle tests correctly, firmly push the reset button to restore power. A distinctive click should be heard or felt when this is complete. IF THE RECEPTACLE DOES NOT RESET PROPERLY, DO NOT USE THE RECEPTACLE. SEE AUTHORIZED DEALER FOR SERVICE IMMEDIATELY.
4. Loads can now be applied to unit.

USING ELECTRIC POWER

⚠ WARNING	
	Risk of electrocution. Make sure that the appliance is switched off before connecting it to the generator.
• DO NOT move the generator while it is running.	

AC APPLICATION

1. Make sure the voltage indicated on the voltmeter is at the normal level (approx. 120V).

NOTICE
This generator is thoroughly tested and adjusted in the factory. If the generator does not produce the specified voltage, consult your nearest authorized dealer.

2. Turn off the switch(es) of the electrical appliance(s) before connecting to the generator.
3. Insert the plug(s) of the electrical appliance(s) into the receptacle.
 - Be sure that the total wattage of all connected appliances does not exceed the rated output of the generator.

⚠ WARNING	
	To take power from the twistlock receptacle, insert the plug into the receptacle, and turn it clockwise to the lock position.
• DO NOT put foreign objects into the plug receptacle.	

4. Turn on the switch of the appliance.

DC Application

The DC terminal is used for trickle charging 12 volt batteries or low amperage drawing DC tools or appliances.. It provides 12V - 8.3A (100W) of maximum power.

Connection of Cable

Connect positive terminal (red) on generator to positive (+) terminal on battery.

Connect negative terminal (black) on generator to negative (-) terminal on battery.

Safety Precautions While Charging a Battery

WARNING	
	An explosive hydrogen gas is discharged through vent holes in the battery during the charging process.
	Do not allow spark or open flame around the generator or battery during the charging process.
Electrolyte fluid can burn eyes and clothing. Be careful to avoid contact. If injured, wash the affected area immediately with large quantities of water and consult a doctor for treatment.	

When charging a large capacity battery or totally discharged battery, excessive current may force the DC breaker to turn off. In such cases, use a battery charger to charge a large battery with AC output.

Battery defects may cause the DC breaker to trip. Check the battery before resetting the DC breaker.

WATTAGE INFORMATION

Some appliances need a “surge” of energy when starting. This means that the amount of electrical power needed to start the appliance may exceed the amount needed to maintain its use.

Electrical appliances and tools normally come with a label indicating voltage, cycles / Hz, amperage (amps) and electrical power needed to run the appliance or tool.

Check with your nearest authorized dealer with questions regarding power surge of certain appliances or power tools.

- Electrical loads such as incandescent lamps and hot plates require the same wattage to start as is needed to maintain use.
- Loads such as fluorescent lamps require 1.2 to 2 times the indicated wattage during start-up.
- Loads for mercury lamps require 2 to 3 times the indicated wattage during start-up.
- Electrical motors require a large starting current. Power requirements depend on the type of motor and its use. Once enough “surge” is attained to start the motor, the appliance will require only 30% to 50% of the wattage to continue running.
- Most electrical tools require 1.2 to 3 times their wattage for running under load during use. For example, a 5000 watt generator can power a 1800 to 4000 watt electrical tool.
- Loads such as submersible pumps and air compressors require a very large force to start. They need 3 to 5 times the normal running wattage in order to start. For example, a 5000 watt generator would only be able to drive a 1000 to 1700 watt pump.

To determine the total wattage required to run a particular electrical appliance or tool, multiply the voltage figure of the appliance / tool by the amperage (amps) figure of same. The voltage and amperage (amps) information can be found on a name plate which is normally attached to electrical appliances and tools.

CAUTION

If an electric motor fails to start or reach running speed, turn off the appliance or tool immediately to avoid equipment damage. Always check the requirements of the tool or appliance being used compared to the rated output of the generator.

SPARK ARRESTER

The spark arrester must be cleaned regularly to keep it functioning as designed.

A clogged spark arrester:

- Prevents the flow of exhaust gas
- Reduces engine output
- Increases fuel consumption
- Makes starting difficult

 CAUTION
--

If engine has been running, the muffler and the spark arrester will be very hot. Allow the muffler to cool before cleaning the spark arrester.
--

HOW TO REMOVE THE SPARK ARRESTER

1. Remove the flange bolts from the muffler cover and remove the muffler cover.
2. Remove the special screw from the spark arrester and remove the spark arrester from the muffler.

CLEAN THE SPARK ARRESTER SCREEN

1. Use a brush to remove carbon deposits from the spark arrester screen.

Be careful to avoid damaging the screen.

2. The spark arrester must be free of breaks and holes. Replace the spark arrester if it is damaged.
3. Install the spark arrester, and muffler protector in the reverse order of disassembly.

If you have any problems with the operation of your generator, please call customer service at 1-800-432-3246. If calling for assistance, please have the model and serial number available.

Stopping The Generator

1. Turn off the power switch of the electric equipment and unplug the cord from receptacle of the generator.
2. Allow the engine about 3 minutes to cool down without load before stopping.
3. Push the engine switch to the OFF position.
4. Push the main switch to the OFF position.

OIL SENSOR

The oil sensor detects a drop in oil level in the crankcase and automatically stops the engine when the oil level drops below a predetermined level.

When the engine has stopped automatically, turn off the generator, and check the oil level. Refill engine oil to the upper level as instructed and restart the engine.

 CAUTION
DO NOT remove oil sensor probe when refilling with oil. Remove oil filler cap on the opposite side of carburetor.

TROUBLESHOOTING CHART

If you are experiencing a problem that is not listed in this chart, or have checked all the possible cause listed and you are still experiencing the problem, see your authorized dealer.

Problem	Cause	Correction
Engine will not start	<ol style="list-style-type: none"> 1. Check if engine switch is off. 2. Fuel Tank empty. 3. Check to make sure generator is not connected to an appliance. 4. Check spark plug for loose spark plug cap 5. Check spark plug for contamination. 6. Check engine oil level. 	<ol style="list-style-type: none"> 1. Turn engine switch to the Choke position. 2. Fill tank ensuring you do not overfill. 3. If connected, turn off the power switch on the connected appliance and unplug. 4. If loose, push spark plug cap back into place 5. Remove spark plug and clean electrode. 6. If engine oil level is low, add oil as per instructions.
Generator has no output	<ol style="list-style-type: none"> 1. Check if the DC circuit breaker is turned off. 2. Check AC receptacle and DC terminals for loose connection. 3. Check to see if engine starting was attempted with appliances already connected to generator. 	<ol style="list-style-type: none"> 1. Depress or flip the circuit breaker into ON position. 2. Secure connection if necessary. 3. Turn off switch on the appliance, and disconnect cable from receptacle. <p>Reconnect after generator has been started properly.</p>

MAINTENANCE SCHEDULE**CAUTION**

Make sure the engine is stopped before starting any maintenance, servicing or repair.

NOTE: *It is recommended to use ear protection when performing operation, maintenance and repair of the generator.*

Maintenance, replacement or repair of the emission control devices and systems must be performed by an authorized dealer.

SERVICE MAINTENANCE CODES

The Hourmeter / Service maintenance code indicator displays service interval reminders.

Code	Action
P-25	Change the oil after the first 25 hours of use.
P-50	Clean the air filter and change the oil after every 50 hours of use.
P-100	Clean the fuel strainer, air filter and change the oil after every 100 hours of use

The code information will be cleared automatically after 0.1 hours of display when restarting the generator.

DAILY INSPECTION

Before running the generator, check the following service items:

- Safe surroundings.
- Leakage of gasoline and engine oil.
- Clean engine oil.
- AC receptacle for damage.
- Enough gasoline.
- Excessive vibration, noise.
- Loose or broken bolts, nuts or shields.
- Clean air element.

PERIODIC MAINTENANCE

Periodic maintenance is vital to safe and efficient operation of your generator. The emission control system consists of the following parts:

- Carburetor and internal parts
- Cold start enrichment system, if applicable
- Intake manifold, if applicable
- Air cleaner element
- Spark plug
- Magneto or electronic ignition system
- Exhaust manifold
- Hoses, connectors, and assemblies

CHANGING ENGINE OIL

Change oil after the first 20 hours of operation. Thereafter it should be changed every 100 hours. **This generator uses SAE 10W30 oil.**

1. Place an oil pan beneath the unit. Drain oil by removing the drain plug and the oil filler cap while the engine is warm, but not hot.
2. Reinstall the drain plug and fill the engine with oil until it reaches the upper level on the oil filler cap.
3. Dispose of used oil according to local zoning or environmental regulations.

SERVICING THE AIR CLEANER

Maintaining the air cleaner in proper condition is very important. Dirt induced through improperly installed, improperly serviced or inadequate elements damages and wears out engines. Always keep the element clean. Never run the generator without the air filter element.

1. Unhook the cover and remove the cleaner element.
2. Urethane foam: Wash the element with fresh water. Squeeze out the water then dry the element. (Do not twist.)

CLEANING AND GAPPING SPARK PLUG

If the plug is contaminated with carbon, remove the carbon using a plug cleaner or wire brush. **Use NGK BPR6ES or equivalent.**

Adjust the electrode gap to 0.6 to 0.7 mm (0.024 to 0.028 in).

CLEANING FUEL STRAINER

Dirt and water in the fuel are removed by the fuel strainer.

1. Remove the strainer cup and throw away water and dirt.
2. Clean the screen and strainer cup with gasoline.
3. Tightly fasten the cup to main body, making sure to avoid fuel leak.

PERIODIC OPERATION AND INSPECTION:

When using the generator as emergency electric power source, periodic operation and inspection are needed.

Fuel (gasoline) and engine oil will deteriorate with time, and cause the engine to be difficult to start and result in improper engine operation and /or failure.

	<p>NOTICE</p>
<p>Since the fuel (gasoline) will deteriorate with time, replace fuel (gasoline) with fresh fuel periodically; every three months or add a fuel stabilizer.</p>	

1. Check the fuel (gasoline), engine oil and air cleaner.
2. Start engine.
3. With appliance such as lighting activated, run the engine for over ten minutes.
4. Check the following items:
 - Engine running properly.
 - Adequate output.
 - Engine switch normally operated.
 - No leakage of engine oil and fuel (gasoline).

TRANSPORTING

When transporting the generator, make sure that the fuel (gasoline) is drained from the tank.

WARNING



To prevent fuel spillage due to the vibration and impact, never transport the generator with fuel (gasoline) in the tank. Secure the tank cap.
To avoid the risk of the gasoline flammability, never leave the generator in an area exposed to direct sunlight or high temperatures for a long period time.

Keep the fuel in an approved storage tank when transporting.

1. Turn the engine switch to the OFF position.
2. Turn fuel valve to the closed position.
3. Drain the fuel from the tank.
4. Tighten the tank cap.

CAUTION

DO NOT place any heavy objects on the generator.

Select and place the generator in the proper position of the transport vehicle so that the generator will not move or fall down. Secure the generator if necessary.

PREPARATION FOR STORAGE

The following procedures should be followed prior to storage of your generator for periods of 6 months or longer.

1. Drain fuel from fuel tank carefully by disconnecting the fuel line. Gasoline left in the fuel tank will eventually deteriorate making engine starting difficult. Add fuel stabilizer to fuel tank.
2. Remove the drain screw of the carburetor.
3. Change engine oil.
4. Check for loose bolts and screws, tighten them if necessary.
5. Clean generator thoroughly with clean cloth. **NEVER USE WATER TO CLEAN GENERATOR.**
6. Pull recoil starter handle until resistance is felt, leaving handle in that position.
7. Store generator in a well ventilated, low humidity area.

BATTERY

The battery used on the EG-10000 is a lithium-ion type battery. The battery is re-charged anytime the unit is operated. If the unit is going to be stored for long periods of time, more than 8-12 months without being used, it is recommended to use a "Battery Tender" to maintain the proper voltage of the battery. ECHO does not offer a battery tender as an accessory, however, battery tenders are widely available. Use a battery tender with a maximum output voltage of 14.5V(DC) and a maximum output current of 1A(DC) that is suitable for Lithium-Ion batteries. The lower the amperage output of the battery tender, the better it is for the long-term durability of the battery. Batteries are hazardous goods. Dispose of them according to local recycling regulations.

Generator Specifications

Engine Model	R420D-V
Start	Manual/Electric
Rated Frequency	60Hz
Rated Voltage	120V/240V
Rated Power	7.5KW
DC Output	12V, 8.3A
Fuel Tank Capacity	25L
Full Load Continuum Running Time	6h
50% Load Continuum Running Time	8h
Noise (7m)	84dB
Specifications for the Panel	2 x GFCI Duplex with water proof cover, 1 x 120V- 30A Twist lock-3prongs with water proof cover, 1 x 120/240V- 30A Twist lock-4 prongs with water proof cover, 3 in 1 digital meter, Auto idle switch, Cigarette lighter
Certification	CSA/EPA/CARB
LOW THD	Yes
Wheels & Kits	Yes

**HIGH ALTITUDE REPLACEMENT KIT FOR EPAIII ENGINES
3000ft to 6000ft or 6000ft to 8000ft of elevation**

At high altitude, the standard carburetor air-fuel mixture will be too rich. Performance will decrease and fuel consumption will increase. A very rich mixture will also foul the spark plug and cause hard starting. Operation at an altitude that differs from that at which this engine was certified, for extended periods of time, may increase emissions.

- The fuel system on this Engine or Equipment may be influenced by operation at higher altitudes. Proper operation can be ensured by installing an altitude kit when required. See the table below to determine when an altitude kit is required. Operating this generator without the proper altitude kit installed may increase the engine's emissions and decrease fuel economy and performance. Kits may be obtained from any Dealer, and should be installed by a qualified individual.

Equipment model*	Fuel	Altitude Range**	Kit Part Number
	Gasoline	0 – 3000 ft	Not Required
		3000 – 6000 ft	Altitude kit 1#
		6000 – 8000 ft	Altitude kit 2#

* Engine, Generator Set, Pressure Washer, Walk-Behind Lawnmower, Compressor, Pump, Tiller etc.

** Elevation above sea level.

* This high altitude jet is to be used at elevations above 3000 feet.

* At elevations above 8000 feet, the engine may experience decreased performance, even with the high altitude kit.

If a carburetor is replaced, the proper high altitude kit jet will need to be installed into the replacement carburetor.

WARNING

To prevent serious injury from fire: Follow the kit procedures in a well-ventilated area away from ignition sources. If the engine is hot from use, shut the engine off and wait for it to cool before proceeding.

NOTICE

The warranty may be void if necessary adjustments are not made for high altitude use.

LIMITED WARRANTY STATEMENT

ECHO Incorporated warrants to the original retail purchaser that this ECHO® brand outdoor product is free from defects in material and workmanship and agrees to repair or replace at ECHO Incorporated's discretion, any defective product free of charge within these time periods from the date of purchase.

- 3 Year Consumer
- 90 Days Commercial
- 90 Days – For Rental Use
- 90 Days Accessories and Replacement Parts

This warranty extends to the original retail purchaser only and commences on the date of the original retail purchase.

Any part of this product found, in the reasonable judgment of ECHO Incorporated, to be defective in material or workmanship will be repaired or replaced without charge for parts and labor by an authorized ECHO dealer. Repair parts and accessories replaced under this warranty are warranted only for the balance of the original warranty period.

The product, including any defective part, must be returned to an authorized ECHO dealer within the warranty period. The expense of delivering the product to the dealer for warranty work and the expense of returning it back to the owner after repair or replacement will be paid by the owner. ECHO Incorporated's responsibility in respect to claims is limited to making the required repairs or replacements and no claim of breach of warranty shall be cause for cancellation or rescission of the contract of sale of any ECHO brand outdoor product. Proof of purchase will be required by the dealer to substantiate any warranty claim. All warranty work must be performed by an authorized ECHO dealer.

This warranty does not cover any product that has been subject to misuse, neglect, negligence, or accident, or that has been operated in any way contrary to the operating instructions as specified in this Operator's Manual. This warranty does not apply to any damage to the product that is the result of improper maintenance or to any product that has been altered or modified. The warranty does not extend to repairs made necessary by normal wear or by the use of parts or accessories which are either incompatible with the ECHO brand outdoor product, or that adversely affect its operation, performance, or durability. In addition, this warranty does not cover wear to normal items such as, but not limited to:

- A. Tune-ups – Air filters, gas filters, carburetors, spark plugs, filters, oil changes
- B. Wear items – Recoil Starter Rope, Motor Brushes, Alternator Brushes, Cotter Pins, Wheels
- C. **IMPORTANT: Some components not covered under this warranty may still be covered by a separate warranty issued by the engine**

manufacturer. Please see the Engine Manufacturer Warranty (if any) supplied with this product for further details.

ECHO Incorporated reserves the right to change or improve the design of this product without assuming any obligation to modify any product previously manufactured.

ALL IMPLIED WARRANTIES ARE LIMITED IN DURATION TO THE STATED WARRANTY PERIOD. ACCORDINGLY, ANY SUCH IMPLIED WARRANTIES INCLUDING MERCHANTABILITY, FITNESS FOR A PARTICULAR PURPOSE, OR OTHERWISE, ARE DISCLAIMED IN THEIR ENTIRETY AFTER THE EXPIRATION OF THE APPROPRIATE THREE-YEAR OR 90 DAY WARRANTY PERIOD. ECHO INCORPORATED'S OBLIGATION UNDER THIS WARRANTY IS STRICTLY AND EXCLUSIVELY LIMITED TO THE REPAIR OR REPLACEMENT OF DEFECTIVE PARTS AND ECHO INCORPORATED DOES NOT ASSUME OR AUTHORIZE ANYONE TO ASSUME FOR THEM ANY OTHER OBLIGATION. SOME STATES DO NOT ALLOW LIMITATIONS ON HOW LONG AN IMPLIED WARRANTY LASTS, SO THE ABOVE LIMITATION MAY NOT APPLY TO YOU. ECHO INCORPORATED ASSUMES NO RESPONSIBILITY FOR INCIDENTAL, CONSEQUENTIAL, OR OTHER DAMAGES INCLUDING, BUT NOT LIMITED TO, EXPENSE OF RETURNING THE PRODUCT TO AN AUTHORIZED DEALER FOR ECHO BRAND OUTDOOR PRODUCTS AND EXPENSE OF DELIVERING IT BACK TO THE OWNER, MECHANIC'S TRAVEL TIME, TELEPHONE OR TELEGRAM CHARGES, RENTAL OF A LIKE PRODUCT DURING THE TIME WARRANTY SERVICE IS BEING PERFORMED, TRAVEL, LOSS OR DAMAGE TO PERSONAL PROPERTY, LOSS OF REVENUE, LOSS OF USE OF THE PRODUCT, LOSS OF TIME, OR INCONVENIENCE. SOME STATES DO NOT ALLOW THE EXCLUSION OR LIMITATION OF INCIDENTAL OR CONSEQUENTIAL DAMAGES, SO THE ABOVE LIMITATION OR EXCLUSION MAY NOT APPLY TO YOU.

This warranty gives you specific legal rights, and you may also have other rights which vary from state to state.

This warranty applies to ECHO brand Generators manufactured by or for ECHO Incorporated and sold in the United States and Canada.

To locate your nearest authorized ECHO dealer, visit www.echo-usa.com or dial 1-800-432-ECHO (3246).

ECHO Incorporated
400 Oakwood Rd. Lake Zurich, IL 60047
1-800-432-ECHO (3246)
www.echo-usa.com



**CALIFORNIA AND FEDERAL EXHAUST AND EVAPORATIVE
EMISSIONS CONTROL WARRANTY STATEMENT**

YOUR WARRANTY RIGHTS AND OBLIGATIONS

The California Air Resources Board, the United States Environmental Protection Agency and Chongqing Rato Technology Co., Ltd. (Rato), are pleased to explain the exhaust and evaporative emissions (“emissions”) control system warranty on your 2019/2020 small off-road engine/equipment.

In California, new equipment that use small off-road engines must be designed, built, and equipped to meet the State’s stringent anti-smog standards. Rato must warrant the emissions control system on your small off-road engine/equipment for the period listed below provided there has been no abuse, neglect or improper maintenance of your small off-road engine/equipment leading to the failure of the emissions control system.

Your emissions control system may include parts such as the carburetor or fuel-injection system, the ignition system, catalytic converter, fuel tanks, fuel lines (for liquid fuel and fuel vapors), fuel caps, valves, canisters, filters, clamps and other associated components. Also included may be hoses, belts, connectors, and other emission-related assemblies.

Where a warrantable condition exists, Rato will repair your small off-road engine/equipment at no cost to you including diagnosis, parts and labor.

MANUFACTURER’S WARRANTY COVERAGE

The exhaust and evaporative emissions control system on your small off-road engine/equipment is warranted for two years. If any emissions-related part on your small off-road engine/equipment is defective, the part will be repaired or replaced by Rato.

OWNER’S WARRANTY RESPONSIBILITIES

As the small off-road engine/equipment owner, you are responsible for performance of the required maintenance listed in your owner’s manual. Rato recommends that you retain all receipts covering

maintenance on your small off-road engine/equipment, but Rato cannot deny warranty coverage solely for the lack of receipts or for your failure to ensure the performance of all scheduled maintenance. As the small off-road engine/equipment owner, you should however be aware that Rato may deny your warranty coverage if your small off-road engine/equipment or a part has failed due to abuse, neglect, or improper maintenance or unapproved modifications.

You are responsible for presenting your small off-road engine/equipment to a Rato distribution center or service center as soon as the problem exists. The warranty repairs shall be completed in a reasonable amount of time, not to exceed 30 days.

If you have questions regarding your warranty coverage, you can email us at echo-usa.custhelp.com/app/ask or contact ECHO Incorporated at 1-800-432-ECHO (3246), web site information is available at WWW.ECHO-USA.COM.

DEFECTS WARRANTY REQUIREMENTS

- A. The warranty period begins on the date the small off-road engine/equipment is delivered to an ultimate purchaser.
- B. General Emissions Warranty Coverage. Rato warrants to the ultimate purchaser and each subsequent owner that the engine or equipment is: Designed, built, and equipped so as to conform with all applicable regulations adopted by the Air Resources Board; and Free from defects in materials and workmanship that causes the failure of a warranted part for a period of two years.
- C. The warranty on emission-related parts will be interpreted as follows:
 1. Any warranted part that is not scheduled for replacement as required maintenance in the written instructions must be warranted for the warranty period defined in Subsection (b)(2). If any such part fails during the period of warranty coverage, it must be repaired or replaced by Rato according to Subsection (4) below. Any such part repaired or replaced under the warranty must be warranted for the remaining warranty period.
 2. Any warranted part that is scheduled only for regular inspection in the written instructions must be warranted for the warranty period defined in Subsection (b)(2). A statement in such written instructions to the effect of "repair or replace as necessary" shall

advise owners of the warranty coverage for emissions related parts. Replacement within the warranty period is covered by the warranty and will not reduce the period of warranty coverage. Any such part repaired or replaced under warranty must be warranted for the remaining warranty period.

3. Any warranted part that is scheduled for replacement as required maintenance in the written instructions must be warranted for the period of time prior to the first scheduled replacement point for that part. If the part fails prior to the first scheduled replacement, the part must be repaired or replaced by Rato according to Subsection (4) below. Any such part repaired or replaced under warranty must be warranted for the remainder of the period prior to the first scheduled replacement point for the part.
4. Repair or replacement of any warranted part under the warranty provisions must be performed at no charge to the owner at a warranty station.
5. Notwithstanding the provisions of Subsection (4) above, warranty services or repairs must be provided at distribution centers that are franchised to service the subject engine/equipment.
6. The owner must not be charged for diagnostic labor that leads to the determination that a warranted part is in fact defective, provided that such diagnostic work is performed at a warranty station.
7. Rato is liable for damages to other engine/equipment components proximately caused by a failure under warranty of any warranted part.
8. Throughout the emissions control system's warranty period set out in subsection (b)(2), Rato must maintain a supply of warranted parts sufficient to meet the expected demand for such parts and must obtain additional parts if that supply is exhausted.
9. Manufacturer-approved replacement parts that do not increase the exhaust or evaporative emissions of the engine or emissions control system must be used in the performance of any warranty maintenance or repairs and must be provided without charge to the owner. Such use will not reduce the warranty obligations of Rato.
10. Add-on or modified parts that are not exempted by the Air Resources Board may not be used. The use of any non-exempted add-on or modified parts will be grounds for disallowing a warranty claim. Rato will not be liable to warrant failures of warranted parts caused by the use of a non-exempted add-on or modified part.
11. Rato issuing the warranty shall provide any documents that

describe that warranty procedures or policies within five working days of request by the Executive Officer.

D - Emission Warranty Parts List for Exhaust

1. Fuel Metering System
 - Carburetor and internal parts (and/or pressure regulator or fuel injection system).
 - Air/fuel ratio feedback and control system.
 - Cold start enrichment system.
2. Air Induction System
 - Controlled hot air intake system.
 - Intake manifold.
 - Air filter.
3. Ignition System
 - Spark Plugs.
 - Magneto or electronic ignition system.
 - Spark advance/retard system.
4. Exhaust Gas Recirculation (EGR) System
 - EGR valve body, and carburetor spacer if applicable.
 - EGR rate feedback and control system.
5. Air Injection System
 - Air pump or pulse valve.
 - Valves affecting distribution of flow.
 - Distribution manifold.
6. Catalyst or Thermal Reactor System
 - Catalytic converter.
 - Thermal reactor.
 - Exhaust manifold.
7. Particulate Controls
 - Traps, filters, precipitators, and any other device used to capture particulate emissions.
8. Miscellaneous Items Used in Above Systems
 - Electronic controls.
 - Vacuum, temperature, and time sensitive valves and switches.
 - Hoses, belts, connectors, and assemblies.

E - Emission Warranty Parts List for Evap

1. Fuel Tank
2. Fuel Cap
3. Fuel Lines (for liquid fuel and fuel vapors)

4. Fuel Line Fittings
5. Clamps*
6. Pressure Relief Valves*
7. Control Valves*
8. Control Solenoids*
9. Electronic Controls*
10. Vacuum Control Diaphragms*
11. Control Cables*
12. Control Linkages*
13. Purge Valves*
14. Gaskets*
15. Liquid/Vapor Separator
16. Carbon Canister
17. Canister Mounting Brackets
18. Carburetor Purge Port Connector

*Note: As they relate to the evaporative emission control system.

Rato will furnish with each new small off-road engine/equipment written instructions for the maintenance and use of the engine/equipment by the owner.



**IF YOU NEED ASSISTANCE WITH THE ASSEMBLY OR OPERATION
OF THIS GENERATOR, PLEASE CONTACT US AT:**

ECHO Incorporated
400 Oakwood Road
Lake Zurich, IL 60047
1-800-432-3246
www.echo-usa.com
E-mail: echo-usa.custhelp.com/app/ask