

700 70546 SHREDDER KIT INSTALLATION INSTRUCTIONS

WARNING DANGER

Shut off the engine before inspecting or servicing any part of the Shredder. Make sure all moving parts have come to a complete stop. Disconnect spark plug wire and negative battery cable on electric start models.

Be careful when replacing chipping knives and shredding knives, these parts are sharp.

NOTE: This Shredder Kit has two additional shredding knives to provide more complete shredding capability. Be sure to install shredding knives properly to maintain rotor balance.

- STEP 1:** Remove rotor shaft end cap.
- STEP 2:** Loosen set screw holding lock collar on the chipper side rotor bearing.
- STEP 3:** Tap the lock collar using a punch and hammer until loose and remove.
- STEP 4:** Remove chipper chute fasteners and chute from frame.
- STEP 5:** Remove socket head bolt and nut from shaft (1) (see drawing on page 13). Slide knife shaft from rotor assembly and discard old shaft, shredding knives, spacers, nut and bolt.
- STEP 6:** Install in shaft one (1) location new shaft, shredding knives, spacers, nut and bolt. Follow order of assembly shown in Figs. 1 & 2 for shaft one (1) on page 13.
- STEP 7:** Repeat steps 5 & 6 for shafts 2, 3 and 4. Be sure to install shredder knives and spacers as shown in Figs. 1 & 2 on page 13 for proper rotor balance.
- STEP 8:** Re-install chipper chute onto frame and tighten fasteners.
- STEP 9:** Adjust chipper knife clearance between chipping knives and chipping blocks to 1/16 to 1/8" as follows:
- A. Remove lower belt guard and discharge screen. Loosen set screw holding lock collars on rear rotor bearing. Loosen lock collar using a punch and hammer until it can be turned and removed.
 - B. Tap end of rotor shaft with rubber mallet until clearance between knife and chipping block is 1/16" to 1/8" for each knife (Fig. 3 on page 13).
 - C. Reinstall lock collars. Turn collar in direction of shaft rotation using a punch and hammer. Tighten set screws.
 - D. Check pulley alignment, using a straightedge. If necessary, loosen set screws on both pulleys and move them so that they are in line. Make sure that idler pulley contacts the center of the belt. Retighten set screws.
 - E. Install lower belt guard and discharge screen.

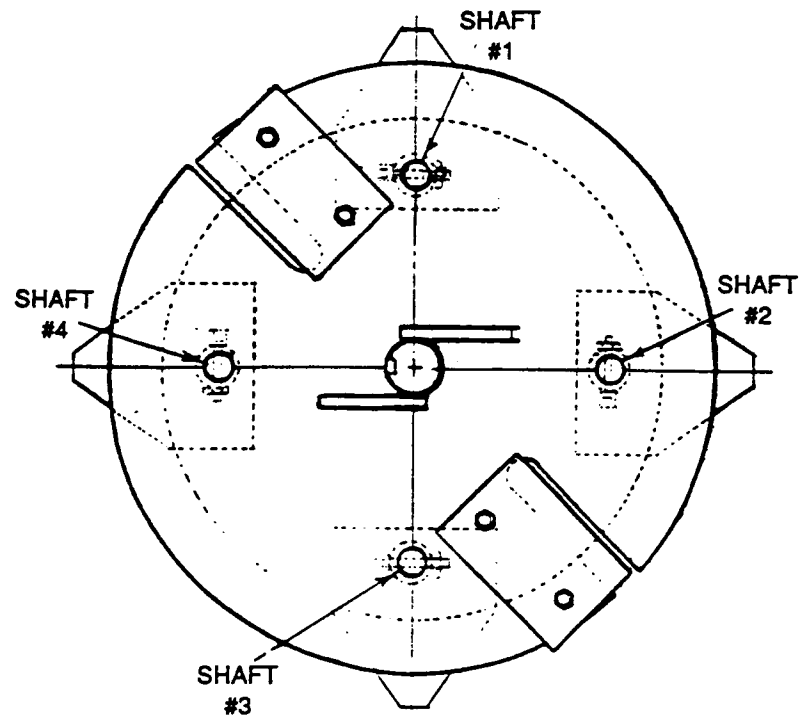

FIG. 1

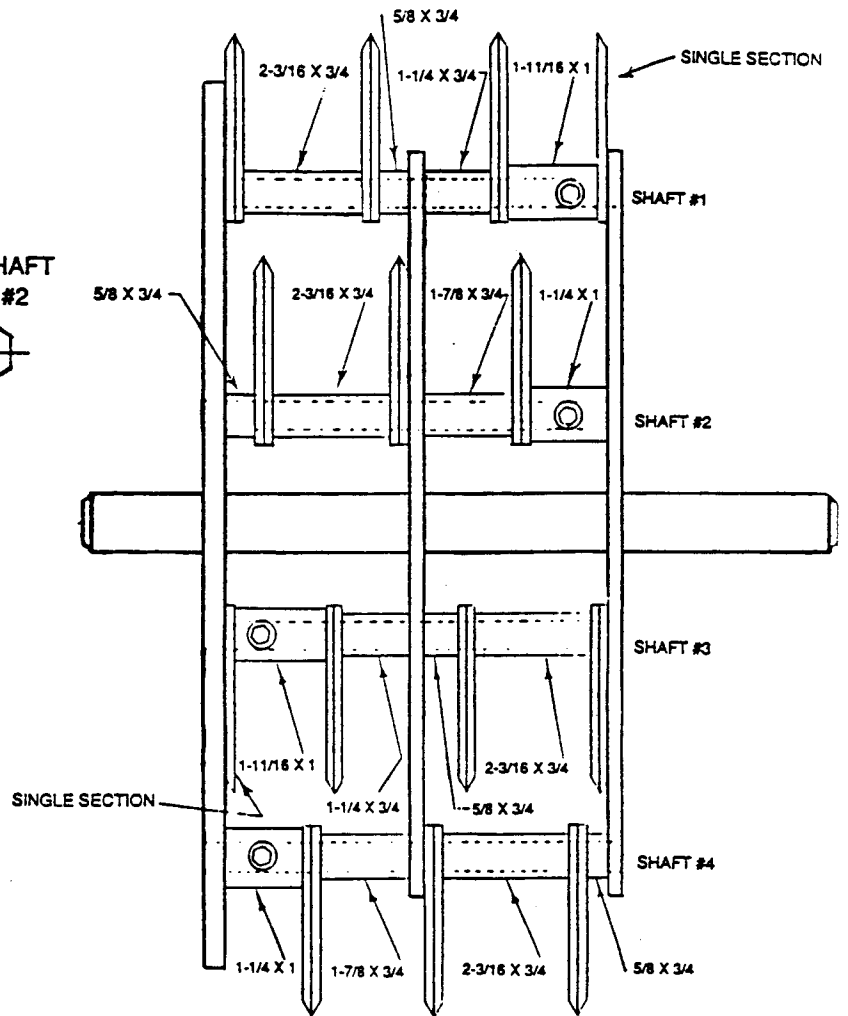

FIG. 2

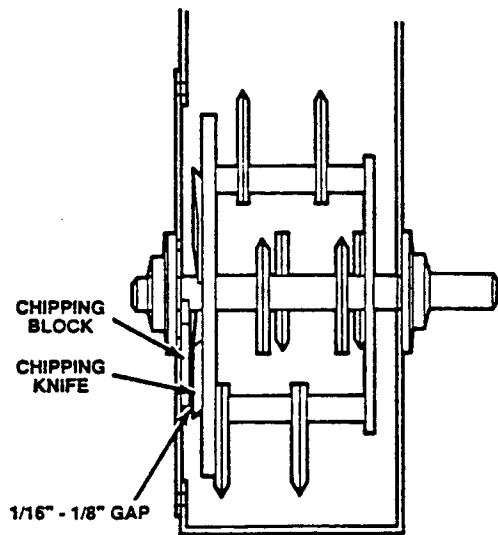

FIG. 3